

SMART-70

User Manual



Copyright Notice

Users must respect the copyright laws applicable in their country. This manual must not be photocopied, translated, reproduced or transmitted in whole or in part for any reason and by the means that might be, albeit electronic or mechanical, without the express, written authorization of IDP Corp., LTD.

All information contained herein may be subject to modification without prior notice. IDP Corp., Ltd. accepts no liability for any possible errors herein, nor for any accidental damage or damage caused through the dissemination or the use of this manual.

Trademarks

SMART-70 is a trademark and IDP is a registered trademark of IDP Corp., LTD. Windows is registered trademark of Microsoft Corp. All other trademarks or registered trademarks are marks of their respective holders. SMART-70 Design is a trademark of IDP Corp., Ltd.

Return Materials Authorization

In order to make a warranty claim you must contact an IDP Reseller. You will be responsible for packaging the printer for shipment and the costs of shipping and insurance of the printer from the point of use of the printer to the IDP Reseller. The IDP Reseller will bear the costs of shipping and insuring the printer from the repair location to the address from which the printer was shipped.

Before returning any equipment for in-warranty or out-of warranty repair, contact an IDP Reseller or an IDP Service Center for a Return Materials Authorization (RMA) number.

Repack the equipment in the original packing material and mark the RMA number clearly on the outside of the box. For more information about RMA or IDP warranty statements, refer to the Warranty booklet on the quick install guide.

Table of Contents

1. INTRODUCTION.....	11
1.1 OVERVIEW.....	11
1.2 MODULES.....	14
1.2.1 Input Hopper.....	14
1.2.2 Printer.....	16
1.2.3 Hybrid Flipper.....	20
1.2.4 Laminator.....	21
1.2.5 Output Hopper.....	25
1.2.6 Stacker.....	27
2. INSTALLATION AND OPERATION.....	28
2.1 HARDWARE INSTALLATION.....	28
2.1.1 Placement of Modules.....	28
2.1.2 Module fastening.....	28
2.1.3 Module connection.....	29
2.1.4 Power connection.....	30
2.1.5 Print ribbon and laminating film installation.....	30
2.1.6 Disposable cleaning roller installation.....	34
2.1.7 Cards Loading.....	37
2.1.8 Loading card cartridge into Output Hopper.....	41
2.1.9 Power on.....	41
2.1.10 Module combination setting.....	42
2.1.11 System status check.....	44
2.1.12 Sample card printing.....	44
2.2 ADVANCED HARDWARE INSTALLATION.....	47
2.2.1 Module ID of SMART-70.....	47
2.2.2 System configuration of SMART-70.....	49
2.2.3 Cable connection of SMART-70.....	51
2.3 SOFTWARE INSTALLATION (WINDOWS VISTA/7/8/10).....	53
3. DRIVER CONFIGURATION.....	58
3.1 PRINTING PREFERENCES.....	58
3.1.1 Printing Preferences.....	58
3.2 ADVANCED SETUP.....	61
3.3 OTHER SETTINGS.....	63

3.3.1 Sharing	63
3.3.2 Ports.....	64
3.3.3 Advanced.....	64
3.3.4 Color Management.....	65
3.3.5 Security.....	65
3.3.6 Printer status check.....	66
4. SMART-70 UTILITIES.....	67
4.1 PRINTER SETTING	67
4.1.1 CardPrinter70Setup.....	67
4.1.2 Basic Setup	68
4.1.3 Advanced Setup	72
4.2 PRINTER TEST.....	75
4.2.1 Printer selection and basic control	76
4.2.2 Print Test	76
4.2.3 Batch Job.....	76
4.2.4 Monitor	76
4.2.5 Printer status.....	77
4.3 FIRMWARE UPGRADE.....	79
4.3.1 Printer connection.....	80
4.3.2 Module Firmware Upgrade.....	80
5. TROUBLESHOOTING.....	82
5.1 PRINTING QUALITY.....	82
5.1.1 Unprinted or wrong colors printed spot.....	82
5.1.2 Unprinted horizontal line.....	82
5.1.3 Blurry or unstable print	82
5.1.4 Not aligned color print.....	83
5.1.5 Unplanned color print.....	83
5.2 CARD SUPPLY.....	84
5.2.1 Card is not supplied or 2 cards are supplied from Input Hopper.....	84
5.3 CARD JAM.....	84
5.3.1 Card jam in Input Hopper	84
5.3.2 Card jam in Printer	86
5.3.3 Card jam in Hybrid Flipper	88
5.3.4 Card jam in Laminator	89
5.3.5 Card jam in Output Hopper.....	91

5.4 CLEANING	92
5.4.1 Input Hopper cleaning.....	92
5.4.2 Printer cleaning	94
5.4.3 Hybrid Flipper cleaning	95
5.4.4 Laminator cleaning	95
5.4.5 Output Hopper cleaning.....	96
5.5 TPH (THERMAL PRINT HEAD) REPLACEMENT	97
5.6 LAMINATOR HEAD REPLACEMENT.....	99
6. SMART-70 SPECIFICATIONS.....	102
6.1 SMART-70 INPUT HOPPER.....	102
6.2 SMART-70 PRINTER.....	102
6.3 SMART-70 HYBRID FLIPPER	103
6.4 SMART-70 LAMINATOR	103
6.5 SMART-70 OUTPUT HOPPER.....	104

Table of Figures

FIGURE 1 COMBINATION OF SMART-70.....	11
FIGURE 2 FRONT SIDE OF INPUT HOPPER.....	15
FIGURE 3 REAR SIDE OF INPUT HOPPER.....	15
FIGURE 4 FRONT SIDE OF PRINTER.....	17
FIGURE 5 REAR SIDE OF PRINTER	17
FIGURE 6 CONTROL PANEL OF PRINTER	18
FIGURE 7 FRONT SIDE OF HYBRID FLIPPER	20
FIGURE 8 REAR SIDE OF HYBRID FLIPPER	21
FIGURE 9 FRONT SIDE OF LAMINATOR	22
FIGURE 10 REAR SIDE OF LAMINATOR.....	23
FIGURE 11 CONTROL PANEL OF LAMINATOR.....	23
FIGURE 12 FRONT SIDE OF OUTPUT HOPPER	26
FIGURE 13 REAR SIDE OF OUTPUT HOPPER	27
FIGURE 14 STACKER	27
FIGURE 15 SMART-70 PLACEMENT OF MODULES	28
FIGURE 16 MODULE FASTENING.....	29
FIGURE 17 MODULE CONNECTION	29
FIGURE 18 POWER CONNECTION	30
FIGURE 19 RIBBON / FILM CARTRIDGE UNLOCKING	30
FIGURE 20 PULLING OUT RIBBON / FILM CARTRIDGE.....	31
FIGURE 21 PRINT RIBBON / LAMINATING FILM MOUNTING.....	31
FIGURE 22 PRINT RIBBON MOUNTING.....	32
FIGURE 23 LAMINATING FILM MOUNTING	32
FIGURE 24 PRINT RIBBON / LAMINATING FILM ALIGNMENT	33
FIGURE 25 RIBBON / FILM CARTRIDGE INSERTION.....	33
FIGURE 26 RIBBON / FILM CARTRIDGE LOCKING.....	34
FIGURE 27 DETACHMENT OF DISPOSABLE CLEANING ROLLER HOLDER	34
FIGURE 28 USED DISPOSABLE CLEANING ROLLER REMOVAL	35
FIGURE 29 NEW DISPOSABLE CLEANING ROLLER MOUNTING.....	35
FIGURE 30 REMOVAL OF NEW DISPOSABLE CLEANING ROLLER PROTECTOR.....	36
FIGURE 31 INSTALLATION OF DISPOSABLE CLEANING ROLLER HOLDER.....	36
FIGURE 32 CARD CARTRIDGE RELEASE FROM INPUT HOPPER	37
FIGURE 33 CARDS THICKNESS ADJUSTMENT	37
FIGURE 34 CARD CARTRIDGE OPEN	38
FIGURE 35 REMOVAL OF THE TAPE FOR FIXING THE WEIGHT	38

FIGURE 36 CARD CARTRIDGE'S WEIGHT FIXING.....	39
FIGURE 37 CARD LOADING.....	39
FIGURE 38 PUTTING DOWN THE CARD CARTRIDGE'S WEIGHT.....	40
FIGURE 39 LOADING CARD CARTRIDGE INTO INPUT HOPPER.....	40
FIGURE 40 LOADING CARD CARTRIDGE INTO OUTPUT HOPPER	41
FIGURE 41 POWER ON	41
FIGURE 42 MODULES COMBINATION CHECKING	42
FIGURE 43 EXISTING MODULES COMBINATION	42
FIGURE 44 ADJUSTED MODULES COMBINATION.....	43
FIGURE 45 SAVED MODULE COMBINATION.....	43
FIGURE 46 COMPLETED MODULE COMBINATION.....	43
FIGURE 47 SYSTEM STATUS CHECKING.....	44
FIGURE 48 PRINTER MENU	44
FIGURE 49 PRINTER MENU (SYSTEM CONFIG).....	45
FIGURE 50 PRINTER MENU (NETWORK CONFIG).....	45
FIGURE 51 PRINTER MENU (PRINTER CONFIG).....	45
FIGURE 52 PRINTER MENU (OPERATION).....	46
FIGURE 53 PRINTER MENU (PRINT SAMPLE)	46
FIGURE 54 SAMPLE CARD.....	46
FIGURE 55 DIP SWITCH LOCATION OF SMART-70 MODULE.....	48
FIGURE 56 SYSTEM CONFIGURATION OF SMART-70.....	49
FIGURE 57 CABLE CONNECTION OF SMART-70 IPHLO.....	51
FIGURE 58 CABLE CONNECTION OF SMART-70 IPP	51
FIGURE 59 CABLE CONNECTION OF SMART-70 IPHLO.....	52
FIGURE 60 CABLE CONNECTION OF SMART-70 IPHPO	52
FIGURE 61 PRINTER DRIVER INSTALLATION 1	53
FIGURE 62 PRINTER DRIVER INSTALLATION 2	53
FIGURE 63 PRINTER DRIVER INSTALLATION 3	53
FIGURE 64 PRINTER DRIVER INSTALLATION 4	53
FIGURE 65 PRINTER DRIVER INSTALLATION 5	54
FIGURE 66 PRINTER DRIVER INSTALLATION 6	54
FIGURE 67 PRINTER DRIVER INSTALLATION 7	54
FIGURE 68 PRINTER DRIVER INSTALLATION 8	54
FIGURE 69 PRINTER DRIVER INSTALLATION 9	55
FIGURE 70 PRINTER DRIVER INSTALLATION 10.....	55
FIGURE 71 PRINTER DRIVER INSTALLATION 11.....	55

FIGURE 72 PRINTER DRIVER INSTALLATION 12.....	55
FIGURE 73 PRINTER DRIVER INSTALLATION 13.....	56
FIGURE 74 PRINTER DRIVER INSTALLATION 14.....	56
FIGURE 75 APPLICATION INSTALLATION 1.....	56
FIGURE 76 APPLICATION INSTALLATION 2.....	57
FIGURE 77 APPLICATION INSTALLATION 3.....	57
FIGURE 78 APPLICATION INSTALLATION 4.....	57
FIGURE 79 APPLICATION INSTALLATION 5.....	57
FIGURE 80 APPLICATION INSTALLATION 6.....	58
FIGURE 81 PRINTER PROPERTIES WINDOW	58
FIGURE 82 LAYOUT	59
FIGURE 83 INPUT / OUTPUT SETTINGS.....	59
FIGURE 84 PRINTING SETTINGS.....	60
FIGURE 85 LAMINATING SETTINGS	60
FIGURE 86 ENCODING SETTINGS	61
FIGURE 87 PRINTER SHARING SETTINGS.....	63
FIGURE 88 PORTS SETTING	64
FIGURE 89 ADVANCED SETTINGS.....	64
FIGURE 90 COLOR MANAGEMENT SETTINGS	65
FIGURE 91 SECURITY SETTING	65
FIGURE 92 PRINTER STATUS CHECK.....	66
FIGURE 93 CARDPRINTER70SETUP LOG-IN	67
FIGURE 94 CARDPRINTER70SETUP START	68
FIGURE 95 BASIC SETUP OF CARDPRINTER70SETUP.....	68
FIGURE 96 COLOR DENSITY	70
FIGURE 97 RESIN BLACK DENSITY	71
FIGURE 98 OVERLAY DENSITY	71
FIGURE 99 ADVANCED SETUP.....	72
FIGURE 100 ARDPRINTER70TEST	75
FIGURE 101 MONITOR.....	76
FIGURE 102 CARDPRINTER70FIRMWARE.....	79
FIGURE 103 MODULES OF SMART-70 SYSTEM (PRINTER, HYBRID FLIPPER).....	80
FIGURE 104 READY FOR FIRMWARE UPGRADE	80
FIGURE 105 MANUAL FIRMWARE UPGRADE.....	81
FIGURE 106 PRINTING QUALITY TROUBLE 1	82
FIGURE 107 PRINTING QUALITY TROUBLE 2	82

FIGURE 108 PRINTING QUALITY TROUBLE 3	82
FIGURE 109 PRINTING QUALITY TROUBLE 4	83
FIGURE 110 PRINTING QUALITY TROUBLE 5	83
FIGURE 111 CARD SUPPLY PROBLEM 1	84
FIGURE 112 CARD JAM IN INPUT HOPPER 1	84
FIGURE 113 CARD JAM IN INPUT HOPPER 2	85
FIGURE 114 CARD JAM IN INPUT HOPPER 3	85
FIGURE 115 CARD JAM IN INPUT HOPPER 4	85
FIGURE 116 CARD JAM IN INPUT HOPPER 5	86
FIGURE 117 CARD JAM IN PRINTER 1	86
FIGURE 118 CARD JAM IN PRINTER 2	86
FIGURE 119 CARD JAM IN PRINTER 3	87
FIGURE 120 CARD JAM IN PRINTER 4	87
FIGURE 121 CARD JAM IN PRINTER 5	87
FIGURE 122 CARD JAM IN HYBRID FLIPPER 1	88
FIGURE 123 CARD JAM IN HYBRID FLIPPER 2	88
FIGURE 124 CARD JAM IN HYBRID FLIPPER 3	88
FIGURE 125 CARD JAM IN HYBRID FLIPPER 4	89
FIGURE 126 CARD JAM IN LAMINATOR 1	89
FIGURE 127 CARD JAM IN LAMINATOR 2	89
FIGURE 128 CARD JAM IN LAMINATOR 3	90
FIGURE 129 CARD JAM IN LAMINATOR 4	90
FIGURE 130 CARD JAM IN LAMINATOR 5	90
FIGURE 131 CARD JAM IN OUTPUT HOPPER 1	91
FIGURE 132 CARD JAM IN OUTPUT HOPPER 2	91
FIGURE 133 CARD JAM IN OUTPUT HOPPER 3	91
FIGURE 134 CARD JAM IN OUTPUT HOPPER 4	92
FIGURE 135 CARD JAM IN OUTPUT HOPPER 5	92
FIGURE 136 INPUT HOPPER CLEANING 1	92
FIGURE 137 INPUT HOPPER CLEANING 2	93
FIGURE 138 INPUT HOPPER CLEANING 3	93
FIGURE 139 INPUT HOPPER CLEANING 4	93
FIGURE 140 PRINTER CLEANING 1	94
FIGURE 141 PRINTER CLEANING 2	94
FIGURE 142 PRINTER CLEANING 3	94
FIGURE 143 HYBRID FLIPPER CLEANING 1	95

FIGURE 144 HYBRID FLIPPER CLEANING 2.....	95
FIGURE 145 LAMINATOR CLEANING 1.....	95
FIGURE 146 LAMINATOR CLEANING 2.....	96
FIGURE 147 LAMINATOR CLEANING 3.....	96
FIGURE 148 OUTPUT HOPPER CLEANING 1.....	96
FIGURE 149 OUTPUT HOPPER CLEANING 2.....	97
FIGURE 150 OUTPUT HOPPER CLEANING 3.....	97
FIGURE 151 TPH REPLACEMENT 1.....	97
FIGURE 152 TPH REPLACEMENT 2.....	98
FIGURE 153 TPH REPLACEMENT 3.....	98
FIGURE 154 TPH REPLACEMENT 4.....	98
FIGURE 155 TPH REPLACEMENT 5.....	99
FIGURE 156 TPH REPLACEMENT 6.....	99
FIGURE 157 LAMINATOR HEAD REPLACEMENT 1.....	99
FIGURE 158 LAMINATOR HEAD REPLACEMENT 2.....	100
FIGURE 159 LAMINATOR HEAD REPLACEMENT 3.....	100
FIGURE 160 LAMINATOR HEAD REPLACEMENT 4.....	100
FIGURE 161 LAMINATOR HEAD REPLACEMENT 5.....	100
FIGURE 162 LAMINATOR HEAD REPLACEMENT 6.....	101

1. Introduction

1.1 Overview

SMART-70 is a high-performance large capacity ID card printer designed by the unique modular concept that can support various printer configurations to meet different user requirements. 500 cards can continuously be printed, laminated and encoded on various card. SMART-70 consists of 5 different modules (① Input Hopper, ② Printer, ③ Hybrid Flipper, ④ Laminator, ⑤ Output Hopper) that can be configured in various combinations according to different customer requirements. Required modules can easily be added to extend functions depending on your needs.

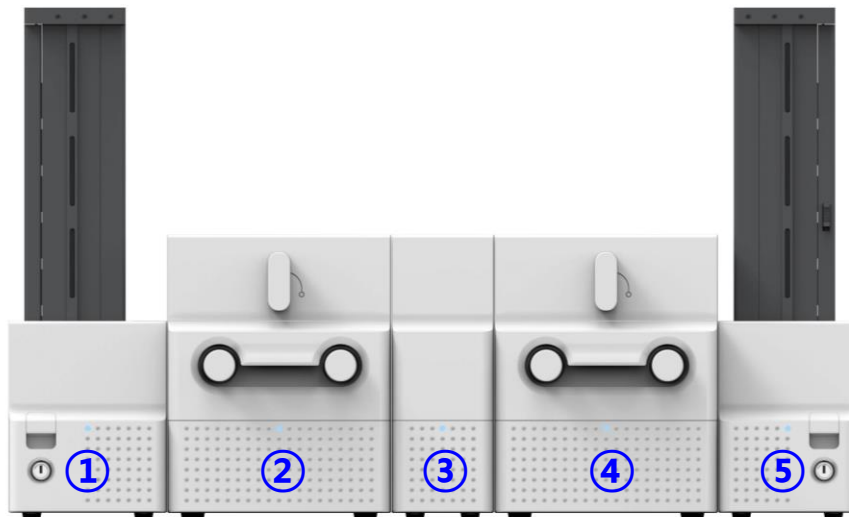

Figure 1 Combination of SMART-70

Key features of SMART-70 are as follows.

- Convenience

SMART-70 is sleekly designed, such as modern household appliances, to provide user-friendly environment with the maximum convenience. Status LED on all modules can indicate the status of each module at all times. Also, LCD and buttons on Printer and Laminator are for user to check the status and set the configuration. Card, print ribbon and other consumables can be changed in intuitive way.

- Flexibility

SMART-70 is designed to organize the combination of SMART-70 by user requirements and easy to add necessary modules or remove unnecessary modules. After purchasing and installing SMART-70 Input Hopper and Printer module for printing, the Laminator can be additionally added when the laminating function is needed.

- Security

For preventing the theft and leakage of cards, ribbons and consumables, physical locking mechanism and Kensington lock are designed and applied on every module. For high-level security, authenticated user can only print, encode and laminate cards by using SMART-70.

- Clear Printing

SMART-70 can print clear images on card by using IDP's FINE Technology that can exquisitely control the heat of print head depending on the picture.

- High Speed

SMART-70 can print 200 cards/hour for color (YMCKO) and 1,000 cards/hour for monochrome. Since each module can independently work, multiple cards can be simultaneously printed, encoded and laminated by the pipeline processing for enhancing issuance speed.

- Reasonable Cost

SMART-70 Series enables a Mass card issuance system to be built by the reasonable cost compared with competitive products. When multi systems built by SMART-70 Series are used, the systems can be substituted for large equipment for card issuance by reasonable cost.

- High Capacity

SMART-70 is designed to support 500 cards capacity in Input Hopper, Printer, Laminator and Output Hopper. Once card, print ribbon and laminating film are replaced, 500 cards can be continuously issued. Also, cards can be loaded and stacked the up to 3000 cards by using multiple Input / Output Hopper.

- Encoding

SMART-70 can encode the magnetic stripe cards and contact/contactless smart cards by using the encoding options, images or 1D/2d barcodes on card can be also read by using image scanner. The magnetic stripe encoder and contactless smart card encoder can be installed into SMART-70 Printer, and the contact/contactless smart card encoder and both-side image scanner can be installed into SMART-70 Hybrid Flipper.

- Energy Saving

SMART-70 is designed to minimize unnecessary power consumption when the system doesn't work. Since SMART-70 Laminator uses the instant direct heating mechanism developed by IDP, it requires no warming-up for laminating and no additional power consumption for maintaining the temperature of the laminate head while on standby.

- Reliability

Since the metal frame, stainless steel shaft and ball bearing is used for the high durability, SMART-70 can be stably operated under the harsh environments of the massive issuance environment.

- Scratch Free

SMART-70 can protect a card surface while the card is in SMART-70 for printing and encoding. 500 cards can be loaded in Input Hopper but the cards can be taken out from Input Hopper without scratch by using the patented load distribution structure of IDP. Also, it is designed that inserted cards don't get in contact with any other components except the rollers for card feeding in Printer, Laminator and other module. In Output Hopper, the stacked cards are lifted up for preventing scratch when a new card is inserted into Output Hopper.

- Software

Since the card design and DB (Database) software for card issuance as well as the printer driver is provided free of charge, users will not need to purchase additional software. Utility programs for adjusting the configuration and checking the status of Printer and powerful SDK (Software Development Kit) for easily developing customized applications are also provided without cost.

1.2 Modules

SMART-70 can organize the card issuing system by combining the 5 different modules. In this case, Printer communicates with the PC and controls the other modules. If Laminator is used without Printer, Laminator will control other modules. This chapter shows the features of each module.

1.2.1 Input Hopper

SMART-70 Input Hopper can be loaded up to 500 cards and supply a card at a time. SMART-70 Input Hopper has the following features.

- LED Indicator on the front side of Input Hopper displays the status of Input Hopper by using the color, so user can intuitively check the status of Input Hopper
- Cards can be conveniently loaded by using large capacity card cartridge which 500 CR80 cards (card thickness 0.8mm) can be loaded.
- The gate of card cartridge can be easily adjusted depending on the thickness of card.
- When card cartridge is taken out from Input Hopper, the gate of cartridge is automatically closed for preventing the loss of cards.
- In order to prevent the theft of cards, physical locking mechanism can prevent card cartridge from being taken out from Input Hopper.
- For solving the problem caused by dust, both sides of card are cleaned when the card is supplied.
- The cleaning device is easily managed by changing the disposable cleaning roller included in new print ribbon package whenever print ribbon is changed.
- Since cards in cartridge pushed by special structure of IDP's patented technology, cards are stably supplied even if the cards are stuck by the static.
- 500 cards are loaded, but the loaded cards don't make scratch because the weight of loaded cards is dispersed when the lowest card has to be supplied.
- When card cartridge is empty, Input Hopper can automatically check and notify the status.

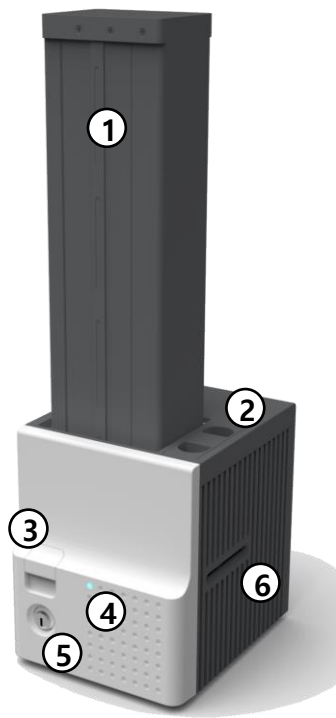

- ① **Card cartridge**
500 cards can be loaded.
- ② **Disposable cleaning roller holder**
Please install the disposable cleaning roller included with new ribbon.
- ③ **Cartridge release button**
Please pull up card cartridge while pressing cartridge release button.
- ④ **Indicator LED**
The status of Input Hopper is displayed by the color.
- ⑤ **Physical lock**
Card cartridge is locked and can't be taken out from Input Hopper.
- ⑥ **Card gate**
Card is supplied to other module.

Figure 2 Front side of Input Hopper



- ① **Kensington lock**
Kensington lock is usable.
- ② **Communication port**
To communicate between SMART-70 modules, please connect to an adjacent module.
- ③ **Serial communication port**
This port is used when an external device controls Input Hopper.
- ④ **Power port**
Please connect the 24V DC power adaptor provided with Input Hopper.
- ⑤ **Power switch**
Turn On/Off

Figure 3 Rear side of Input Hopper

1.2.2 Printer

SMART-70 Printer is the high-end printer which the IDP's printing technologies are concentrated. SMART-70 Printer can continuously print 500 cards of color or 3000 cards of mono, and the magnetic stripe and contactless encoding option can be installed.

SMART-70 Printer has the following features.

- LCD and 4 buttons on the control panel of Printer are for user conveniences and users can easily check the status of Printer and adjust the configuration.
- Indicator LED on the front side of Printer displays the status of Printer by using the color, so user can intuitively check the status of Printer.
- For improving the convenience of changing print ribbon, ribbon cartridge is designed as the drawer type and the print ribbon can easily be changed.
- By using ribbon cartridge lock lever, ribbon cartridge can easily be locked and print head can be moved up and down for the convenience of maintenance.
- For the prevention of thefts, physical locking mechanism and Kensington lock are designed and applied to Printer.
- Ethernet port is installed by default and user can print and encode cards via network.
- For massive card issuance, metal frame, stainless steel shaft, ball bearing and high quality materials are used to increase the stability and reliability of Printer.
- In order to prevent scratch on cards, Printer is designed that cards don't get in contact with any other components except rollers when cards are being fed in Printer.
- High printing speed and improved printing algorithm can guarantee a more vivid and fine printing quality.
- Since card design and DB (Database) software for card issuance as well as printer driver and utility programs are provided free of charge, additional software is not needed to purchase.

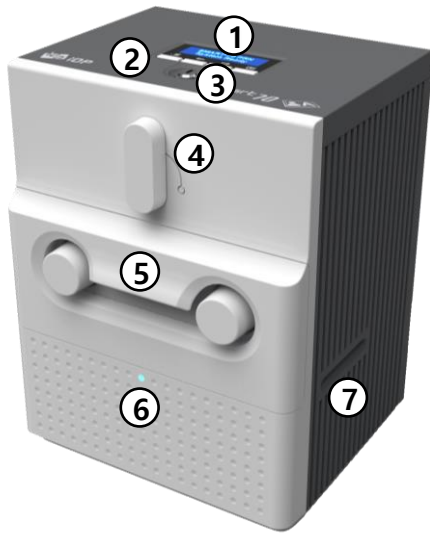

- ① **Control panel LCD**
The status of Printer is displayed.
- ② **Control panel buttons**
Buttons are used to adjust configuration and check status.
- ③ **Physical lock**
Physical lock is to lock Printer and ribbon cartridge.
- ④ **Ribbon cartridge lock lever**
To pull out ribbon cartridge, please turn lever to the right 90 degrees for taking.
- ⑤ **Ribbon cartridge**
Color ribbon for 500 cards or mono ribbon for 3000 cards is loaded into ribbon cartridge.
- ⑥ **Indicator LED**
The status of Printer is displayed by the color.
- ⑦ **Card gate**
Card gate is to convey cards from module to module.

Figure 4 Front side of Printer



- ① **Kensington lock**
Kensington lock is usable.
- ② **Communication port**
To communicate between SMART-70 modules, please connect to an adjacent module.
- ③ **Serial communication port**
This port is to communicate with external device except SMART-70 modules.
- ④ **Ethernet port**
This port is for network communication.
- ⑤ **USB host communication port**
- ⑥ **USB device port**
To communicate with PC, please connect to PC.
- ⑦ **Power port**
Please connect the 24V DC power adaptor provided with Input Hopper.
- ⑧ **Power switch**
Turn On/Off.

Figure 5 Rear side of Printer

Control panel of Printer consists of 2 lines LCD and 4 buttons. The 4 buttons have the functions as shown in the figure 6.



Figure 6 Control panel of Printer

The menus of the control panel of Printer are as below table.

Menu	Submenu	Description
>System Config.	>>Combination	To set module combination. Refer to the chapter 2.1.10 for modules combination setting.
	>>Operation Mode	To set Printer as a Master device. Default is Master.
	>>Insert Dir	To set the direction of Card In. Default is the left.
	>>Eject Dir	To set the direction of Card Out. Default is the right.
	>>Auto Card In	To set the automatic card feeding when the card is detected at the direction of Card In. Default is OFF.
	>>UserCounterClear	To reset user issue count.
>Network Config.	>>DHCP	To set whether to use DHCP function. Default is On.
	>>IP Address	IP address to be used when DHCP is OFF.
	>>Network Mask	Network Mask to be used when DHCP is OFF.
	>>Gateway	Gateway address to be used when DHCP is OFF.
>Print Config.	>>XStartPosition	To set the start position of the printing on the card's X-axis (shorter side).
	>>YStartPosition	To set the start position of the printing on the card's Y-axis (longer side).
	>>YEndPosition	To set the end position of the printing on the card's Y-axis.

	>>YScale	To set the length of printed image on the card's Y-axis.
	>>TotalDensity	To set the total printing density.
	>>ColorDensity	To set the color density
	>>BlackDensity	To set the resin black density.
	>>OverlayDensity	To set overlay density.
	>>RMP+	To adjust the force for pulling print ribbon during printing when the residual quantity of print ribbon is in its maximum quantity.
	>>RMP-	To adjust the force for pulling print ribbon during printing when the residual quantity of print ribbon is in its minimum quantity.
	>>RMM+	To adjust the force for pulling print ribbon during alignment when the residual quantity of print ribbon is in its maximum quantity.
	>>RMM-	To adjust the force for pulling print ribbon during alignment when the residual quantity of print ribbon is in its minimum quantity.
	>>HeadResister	To set resistance value of TPH (Thermal Print Head).
>Operation	>>Print Sample	To print a sample card.
>Information	>>Printer Serial	To show the serial number of Printer.
	>>Firmware Ver.	To show the firmware version of Printer.
	>>Head Serial	To show the serial number of TPH.
	>>Ribbon Balance	To show the print ribbon type and balance.
	>>IP Address	To show the current IP address of Printer.
	>>Network Mask	To show the current Network mask of Printer.
	>>Gateway	To show the current Gateway of Printer.
	>>MAC Address	To show the MAC address of Printer.
	>>User Count	To show the number of issued cards that user can reset.
	>>Factory Count	To show the number of accumulated issued cards after factory shipment.

1.2.3 Hybrid Flipper

SMART-70 Hybrid Flipper can flip over a card for dual sided printing and laminating. And, encoding option and image scanner can be installed into the Hybrid Flipper b option. When the encoder or/and scanner is not installed, the error card bin to collect encoding failed cards is installed by default. After removing the error card bin, the encoder or/and scanner can be installed.

SMART-70 Hybrid Flipper has following features.

- LED Indicator on the front side of Hybrid Flipper displays the status of Hybrid Flipper by using the color, so user can intuitively check the status of Hybrid Flipper.
- 30 error cards (encoding failed cards) can be collected in the error bin.
- The contact/contactless smart card encoder and both-side image scanner option can be installed instead of the error card bin.
- For the prevention of thefts, physical locking mechanism and Kensington lock are designed and applied to Hybrid Flipper.

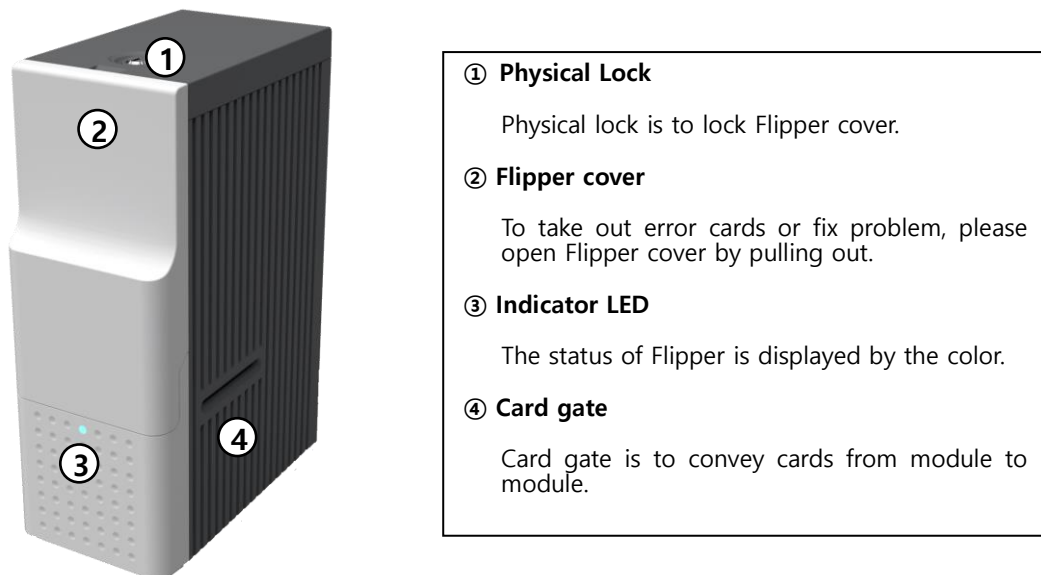

Figure 7 Front side of Hybrid Flipper



- ① **Kensington lock**
Kensington lock is usable.
- ② **Communication port**
To communicate between SMART-70 modules, please connect to an adjacent module.
- ③ **Power port**
Please connect the 24V DC power adaptor provided with Flipper.
- ④ **Power switch**
Turn On/Off
- ⑤ **USB host communication port**
To communicate with SMART-70 Printer via USB when encoder or/and scanner is installed.

Figure 8 Rear side of Hybrid Flipper

1.2.4 Laminator

SMART-70 Laminator is the high performance laminator which cards are can be laminated with high quality without warming-up by using the patented technology of the IDP’s “Instant direct heating mechanism”. One roll of the holographic or clear laminating film can laminate 500 cards.

SMART-70 Laminator has following features.

- LCD and 4 buttons on the control panel are for user conveniences and users can easily check the status of Laminator and adjust configuration.
- Indicator LED on the front side of Laminator displays the status of Laminator by using the color, so user can intuitively check the status of Laminator.
- For improving the convenience of changing a laminating film, film cartridge is designed as the drawer type and laminating film can easily be changed.
- By using film cartridge lock lever, film cartridge can easily be locked and laminate head can be moved up and down for the convenience of maintenance.
- For the prevention of thefts, physical locking mechanism and Kensington lock are designed and applied to Laminator.

- For massive card issuance, metal frame, stainless steel shaft, ball bearing and high quality materials are used to increase the stability and reliability of Laminator.
- Conventional laminators must be needed warming-up time before laminating, but SMART-70 Laminator can immediately laminate without having to wait by using IDP's Instant direct heating mechanism.
- Instant direct heating mechanism of IDP uses bar-type laminate head to instantly increase the temperature of laminate head and to reduce energy consumption to one-seventh level compared with conventional method and to increase the lifespan of laminate head.
- In order to prevent scratch on cards, Laminator is designed that cards don't get in contact with any other components except rollers when cards are being fed in Laminator.

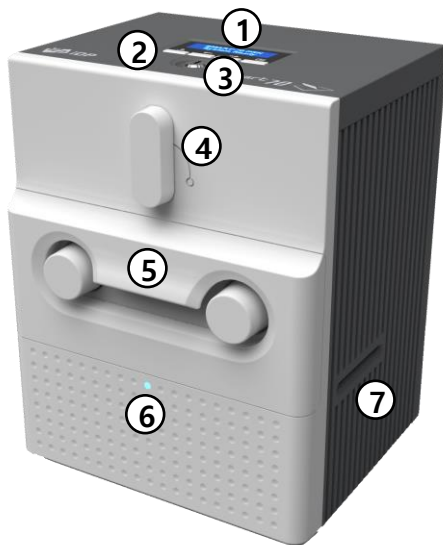

- | |
|---|
| <p>① Control panel LCD
The status of Laminator is displayed.</p> <p>② Control panel buttons
Buttons are used to adjust configuration and check status.</p> <p>③ Physical lock
Physical lock is to lock Laminator and film cartridge.</p> <p>④ Film cartridge lock lever
To pull out film cartridge, please turn lever to the right 90 degrees.</p> <p>⑤ Film cartridge
Laminating film for 500 cards is loaded into cartridge. Ribbon cartridge in Printer can't be used for Laminator.</p> <p>⑥ Indicator LED
The status of Laminator is displayed by the color.</p> <p>⑦ Card gate
Card gate is to convey cards from module to module.</p> |
|---|

Figure 9 Front side of Laminator

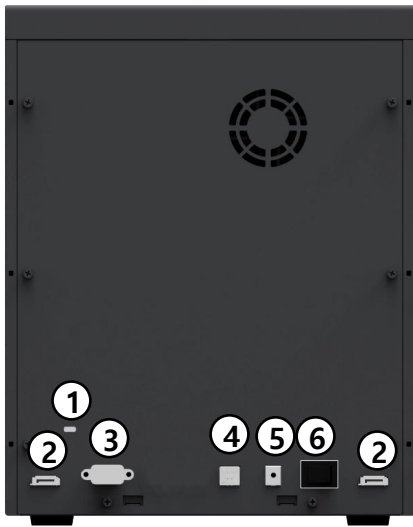

- ① **Kensington lock**
Kensington lock is usable
- ② **Communication port**
To communicate between SMART-70 modules, please connect to an adjacent module.
- ③ **Serial communication port**
This port is to communicate with external device except SMART-70 modules.
- ④ **USB device port**
When Laminator is used without the Printer, this port is to communicate with PC.
- ⑤ **Power port**
Please connect the 24V DC power adaptor provided with Laminator.
- ⑥ **Power switch**
Turn On/Off

Figure 10 Rear side of Laminator

Control panel of Laminator consists of 2 lines LCD and 4 buttons. The 4 buttons have the functions as shown in the figure 11



Figure 11 Control panel of Laminator

The menus of the control panel of Laminator are as below table.

Menu	Submenu	Description
>System Config.	>>Operating Mode	To determine whether Laminator is used as the main control device of SMART-70 system or not. When Laminator is used with Printer, this mode is set to Slave. When Laminator is used alone, this mode is set to Master. Default is Slave.
	>>UserLami.Count	To initialize the user issue laminating count.
	>>In Direction	To set the direction of Card In. Default is the left.
	>>Out Direction	To set the direction of Card Out. Default is the right.
	>>Auto Card In	The Laminator draws in a card automatically when the card is detected at the gate of Card In. Default is On.
	>> Lamine Side	To select the laminating side of the card when Operating Mode is Master. Default is Null Side.
>Lamination Cfg	>>Lami.StartPOS.	To adjust the position of patch to be attached on a card[0 ~ 200]. When the value of Lami.StartPOS is bigger, the laminating patch is attached on more back side of card. When the value of Lami.StartPOS is smaller, the laminating patch is attached on more front side of card. Default is 52.
	>>Lami.Temp	To adjust the temperature for laminating[90 ~ 200]. Default is 160.
	>>Head Resister	The resistance of temperature sensor is registered when Laminator Head Ver.2 is used [39.0 ~ 56.0].
>Extra Config	>>Lami Width	To adjust the distance that Laminator Head attaches the patch from Head Down to Up[5500 ~ 6500]. As the value of Lami Width is bigger, the distance of attached patch is longer. As the value of Lami

		Width is smaller, the distance of attached patch is shorter. Default is 5950.
	>>Lami Speed	To adjust the Laminating Speed[400 ~ 800]. As the value of Lami Speed is bigger, the laminating speed is faster. As the value of Lami Speed is smaller, the laminating speed is slower. Default is 550.
	>>Lami Torque+	To adjust the torque of motor to move a patch when the residual quantity of patch is in its maximum quantity [400 ~ 1000]. As the value of Lami Torque+ is bigger, the motor moves with big force. As the value is smaller, the motor moves with small force. Default is 600.
	>>Lami Torque-	To adjust the torque of motor to move a patch when the residual quantity of patch is in its minimum quantity [400 ~ 1000]. As the value of Lami Torque- is bigger, the motor moves with big force. As the value is smaller, the motor moves with small force. Default is 700.
>Information	>>Lami. Version	To display the firmware version of Laminator.
	>> Serial Number	To display the serial number of Laminator.
	>>Film Type	To display the film type installed in Laminator.
	>>Fac.Lami.Count	To display the laminating count after shipping from factory.
	>>UserLami.Count	To display the laminating count after user initializes
	>>User Count	To display the firmware version of Laminator.
	>>Factory Count	To display the serial number of Laminator.

1.2.5 Output Hopper

SMART-70 Output Hopper can stack with 500 cards after printing, laminating and encoding.

SMART-70 Output Hopper has the following features.

- LED Indicator on the front side of Output Hopper displays the status of Output Hopper by using the color, so user can intuitively check the status of Output Hopper.
- Cards can be conveniently collected by large capacity cartridge which 500 CR80 cards (card thickness 0.8mm) can be loaded.
- When card cartridge is taken out from Output Hopper, the gate of card cartridge is automatically closed for preventing the loss of cards.
- In order to prevent the theft of cards, physical locking mechanism can prevent card cartridge from being taken out from Output Hopper.
- When card cartridge is full, Output Hopper can automatically check and notify the status.
- When a card is inserted into Output Hopper, stacked cards are lifted up by the support beam what is operated by internal CAM to protect card from scratch.
- Same card cartridge is used for Input Hopper and Output Hopper, so card cartridge can be shared.

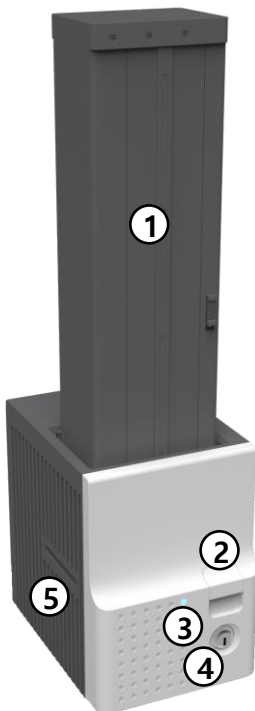

- | |
|--|
| <p>① Card cartridge
500 cards can be loaded.</p> <p>② Cartridge release button
Please pull up card cartridge while pressing cartridge release button.</p> <p>③ Indicator LED
The status of Output Hopper is displayed by the color.</p> <p>④ Physical lock
Card cartridge is locked and can't be taken out from Output Hopper.</p> <p>⑤ Card gate
Card is inserted from other module.</p> |
|--|

Figure 12 Front side of Output Hopper



- ① **Kensington lock**
Kensington lock is usable.
- ② **Serial communication port**
This port is used when external device needs to control Output Hopper.
- ③ **Power port**
Please connect the 24V DC power adaptor provided with Output Hopper.
- ④ **Power switch**
Turn On/Off.
- ⑤ **Communication port**
To communicate between SMART-70 modules, please connect to an adjacent module.

Figure 13 Rear side of Output Hopper

1.2.6 Stacker

If Output Hopper is not needed, 100 cards can be ejected and loaded by using the Stacker provided with Input Hopper.



Figure 14 Stacker

2. Installation and operation

2.1 Hardware installation

2.1.1 PLACEMENT OF MODULES

SMART-70 modules need to be placed on a flat table. Order of placing modules from left to right is Input Hopper, Printer, Laminator and Output Hopper. When some module is not required, please remove unnecessary modules from above placing order. For example, when Laminator is not needed, Input Hopper, Printer, Hybrid Flipper and Output Hopper can be placed.

When more than one same modules are needed or encoding options installed into Hybrid Flipper, please refer to 2.2 Advanced Hardware Installation.



Figure 15 SMART-70 Placement of modules

2.1.2 MODULE FASTENING

모든 모듈들을 그림과 같이 클램프를 사용해서 고정합니다. 클램프를 바닥에 놓고 모듈의 뒤쪽을 클램프의 꺾인 부분에 맞춰서 내려 놓으면 됩니다.



Figure 16 Module fastening

2.1.3 MODULE CONNECTION

Please connect the red communication cables provided with the modules to each module.



Figure 17 Module connection

2.1.4 POWER CONNECTION

Please connect the 24V DC power adaptors provided with each module to all modules. Printer must be connected to the 24 DC power adaptor provided with Printer.

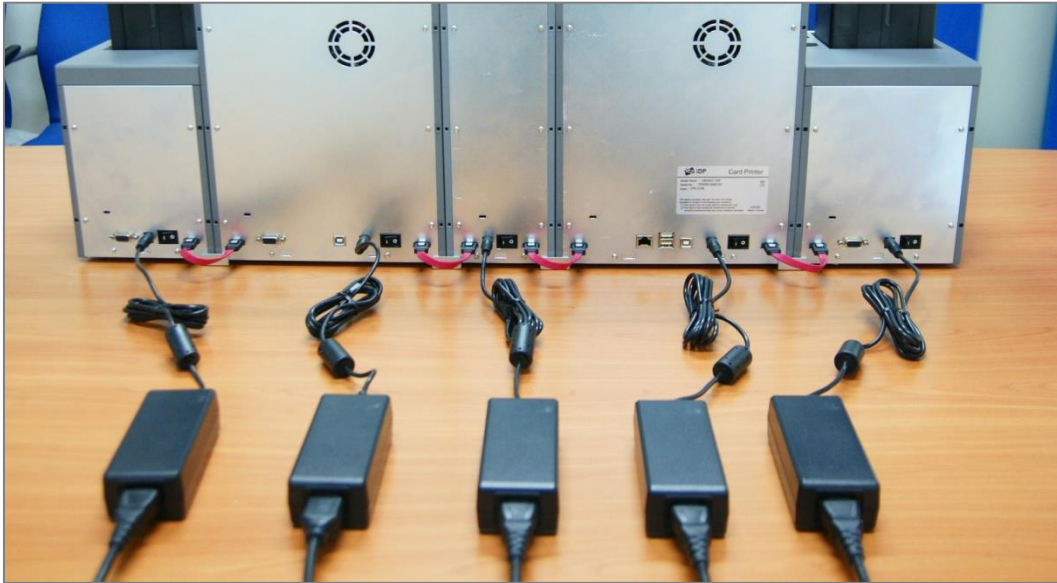

Figure 18 Power connection

2.1.5 PRINT RIBBON AND LAMINATING FILM INSTALLATION

A. Please turn ribbon / film cartridge lock lever to the clockwise 90 degrees.



Figure 19 Ribbon / film cartridge unlocking

B. Please pull out ribbon / film cartridge.



Figure 20 Pulling out ribbon / film cartridge

C. Please mount print ribbon / laminating film by pushing cores into cartridge from the side of cartridge as figure. To properly mount print ribbon or laminating film, please refer to the install guideline on the print ribbon or laminating film box. Ribbon cartridge in Printer is different with film cartridge in Laminator, so the cartridges can't be shared. The ribbon cartridge must be used in Printer and the film cartridge must be used in Laminator.

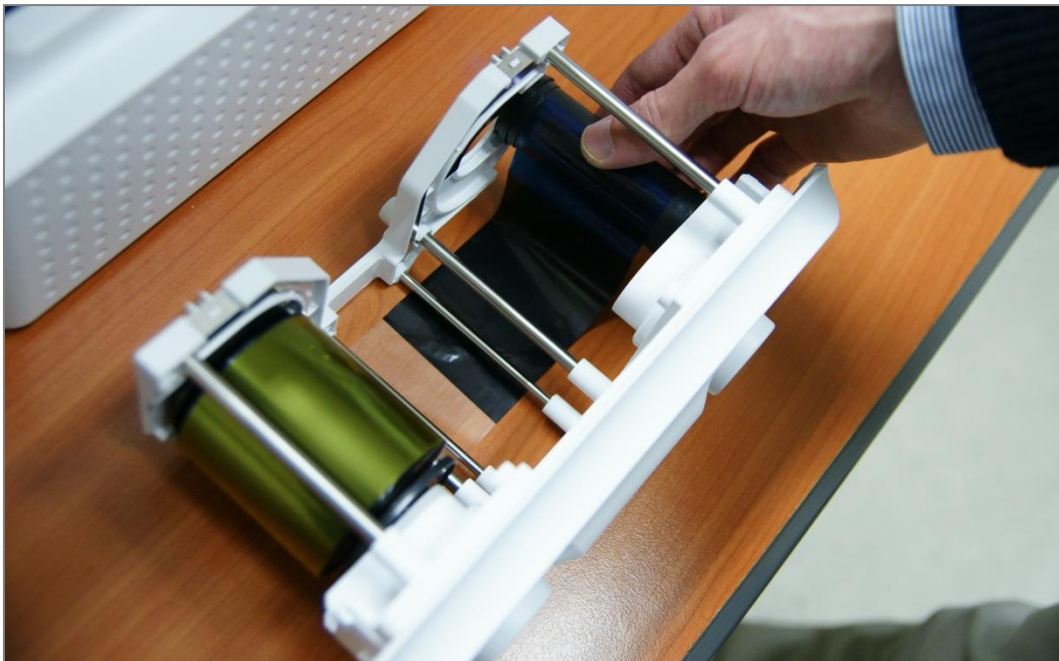

Figure 21 Print ribbon / laminating film mounting

When print ribbon is being mounted, please refer to the mounting instruction on the inside of ribbon cartridge as shown as figure.

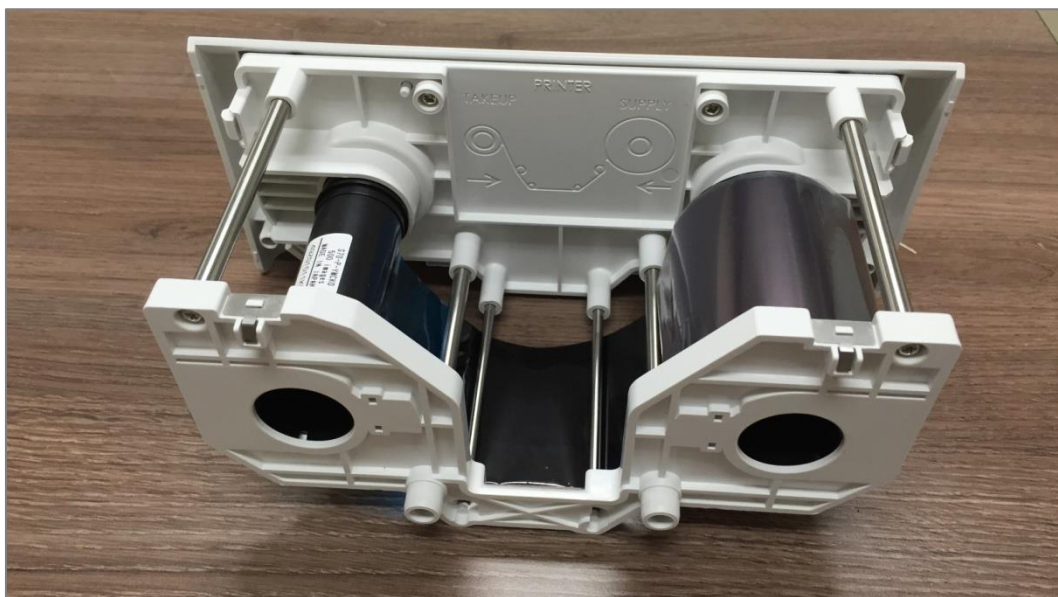

Figure 22 Print ribbon mounting

When laminating film is being mounted, please refer to the mounting instruction on the inside of film cartridge as figure. If vertical laminating position on card is needed to adjust, please use the lever marked by red circle.

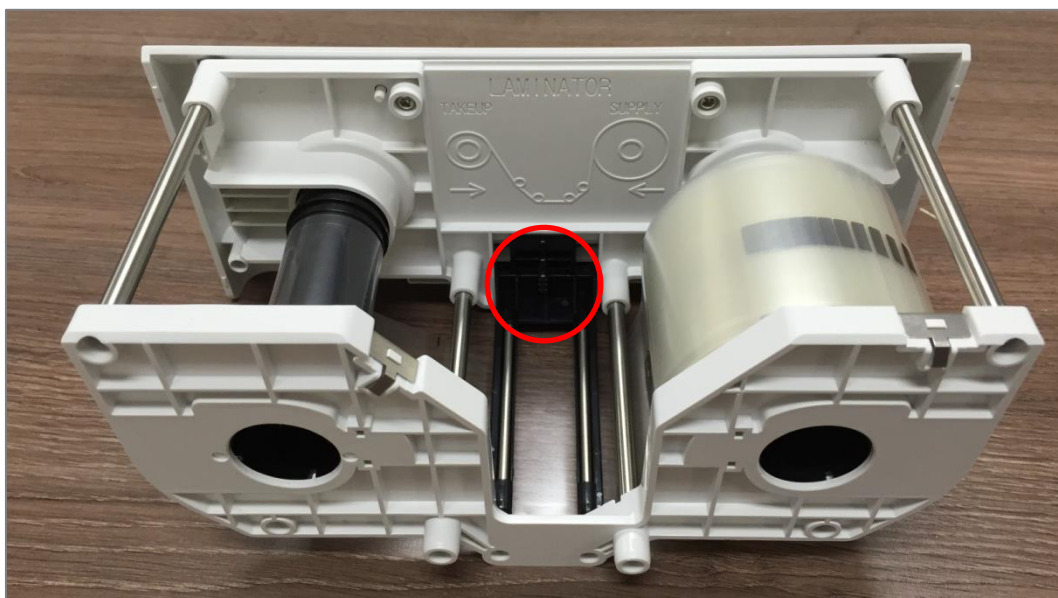

Figure 23 Laminating film mounting

D. Please turn the dial on the right side of cartridge to tension print ribbon or laminating film as figure.



Figure 24 Print ribbon / laminating film alignment

E. Please push ribbon or film cartridge into Printer or Laminator.



Figure 25 Ribbon / film cartridge insertion

F. Please turn ribbon / film cartridge lock lever to the counterclockwise 90 degrees, so the lever is returned to the vertical.



Figure 26 Ribbon / film cartridge locking

2.1.6 DISPOSABLE CLEANING ROLLER INSTALLATION

A. Please detach disposable cleaning roller holder from Input Hopper as figure.



Figure 27 Detachment of disposable cleaning roller holder

B. Please remove used disposable cleaning roller from holder.

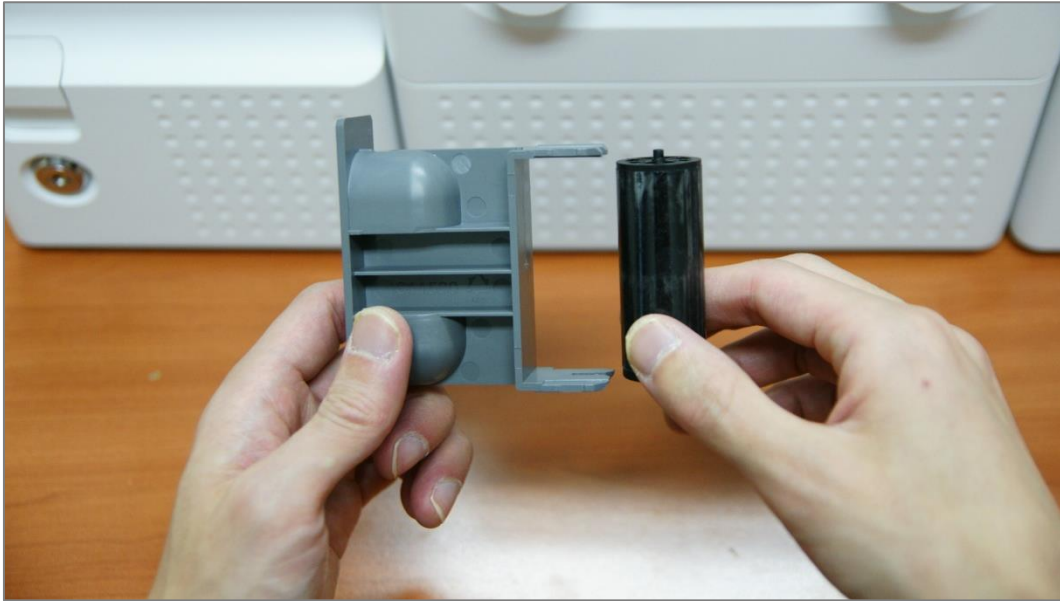

Figure 28 Used disposable cleaning roller removal

C. Please mount a new disposable cleaning roller.

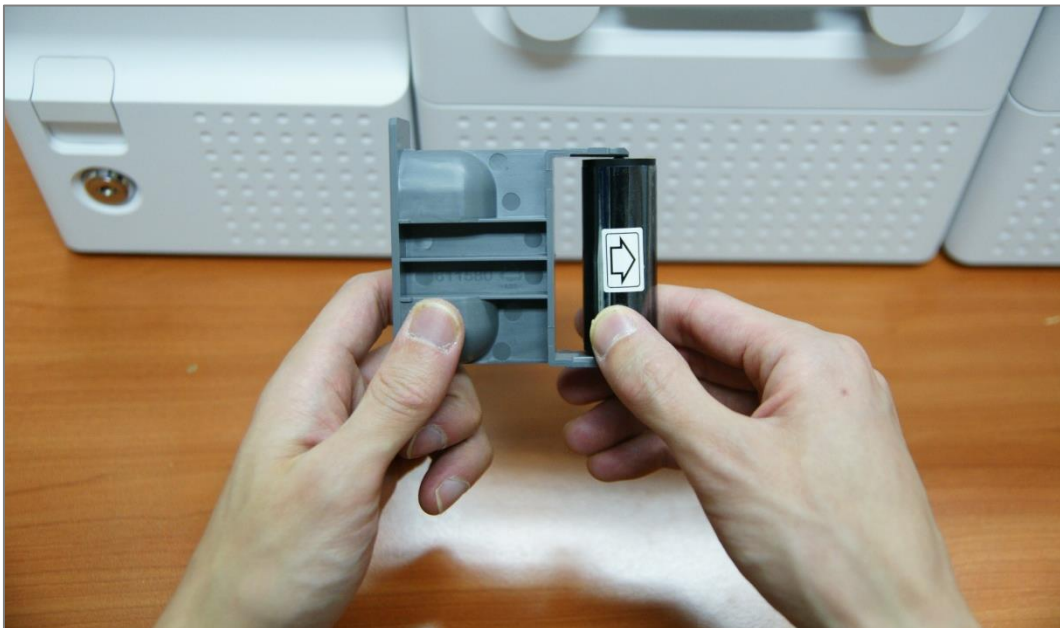

Figure 29 New disposable cleaning roller mounting

D. Please peel off the protector of disposable cleaning roller.



Figure 30 Removal of new disposable cleaning roller protector

E. Please install disposable cleaning roller holder into Input Hopper as figure.



Figure 31 Installation of disposable cleaning roller holder

2.1.7 CARDS LOADING

A. Please pull up card cartridge while pressing cartridge release button.



Figure 32 Card cartridge release from Input Hopper

B. Please adjust the gate of card cartridge depending on card thickness by using control lever.



Figure 33 Cards thickness adjustment

C. Please push the button on card cartridge down and open cartridge cover as figure.



Figure 34 Card cartridge open

D. Please remove the tape for fixing the weight in card cartridge as figure.



Figure 35 Removal of the tape for fixing the weight

E. Please pull up the weight and fix it to the top.



Figure 36 Card cartridge's weight fixing

F. Please take care not to touch the surface of cards and load the cards into cartridge.



Figure 37 Card loading

G. Please put down the weight on loaded cards as figure.



Figure 38 Putting down the card cartridge's weight

H. Please close card cartridge cover and put card cartridge into Input Hopper until click is heard.



Figure 39 Loading card cartridge into Input Hopper

2.1.8 LOADING CARD CARTRIDGE INTO OUTPUT HOPPER

Please put an empty card cartridge into Output Hopper until click is heard. In order to take card cartridge out, please pull up the cartridge while pressing cartridge release button.



Figure 40 Loading card cartridge into Output Hopper

2.1.9 POWER ON

Please turn on the power switch on the rear side of all modules.

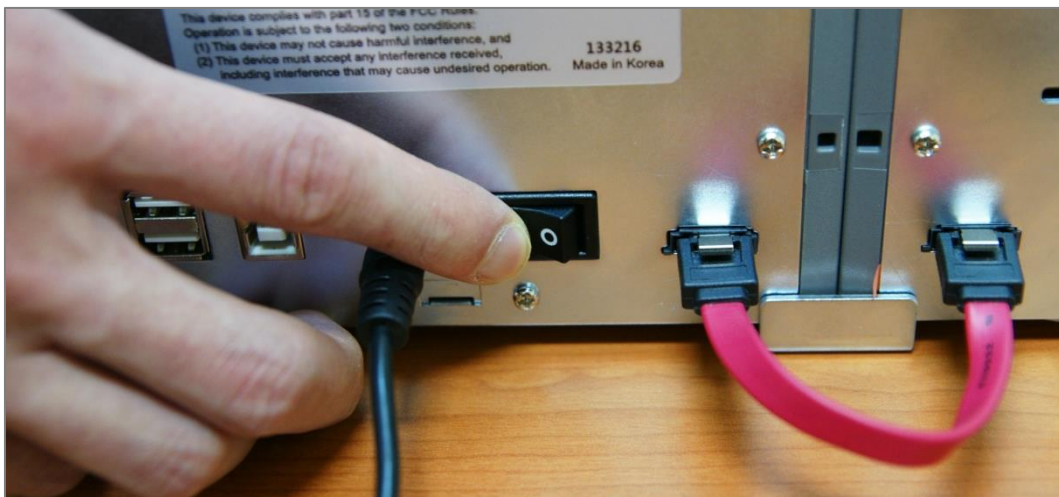

Figure 41 Power on

2.1.10 MODULE COMBINATION SETTING

Since SMART-70 is operated by the combination of multiple modules, the configuration for multiple modules combination must be set during the first installation of the modules. Printer module acts as master who is responsible to communicate with PC and control other modules, and if Printer module is not connected, Laminator module will act as master. The configuration for multiple modules combination can be set in the control panel of Printer module as below. SMART-70 Printer searches connected modules in booting, if the combination of connected modules is different with the configuration for multiple modules combination, Indicator LED is turned to yellow and the message for checking modules combination is displayed. Please follow below steps to set the configuration for multiple modules combinations for initial setting.

- A.** The modules combination is IPFLO (Input Hopper + Printer + Hybrid Flipper + Laminator + Output Hopper) but the configuration is different with the actually connected modules, so the configuration for multiple modules combination must be set again.

Please press the [Select] button indicated by red arrow.



Figure 42 Modules combination checking

- B.** Existing modules combination is shown. Please press the [Select] button indicated by red arrow to adjust the configuration for multiple modules combination.



Figure 43 Existing modules combination

C. The detected modules combination is shown. Please press the [Select] button indicated by red arrow to save the configuration for detected multiple modules combination.



Figure 44 Adjusted modules combination

D. The saved multiple modules combination is shown.



Figure 45 Saved module combination

E. Please wait a while until system is ready.



Figure 46 Completed module combination

2.1.11 SYSTEM STATUS CHECK

Please check that indicator LEDs on all modules are blue and the status of Printer and Laminator is ready.



Figure 47 System status checking

2.1.12 SAMPLE CARD PRINTING

A. Please press the "Menu" button indicated by red arrow on Printer.



Figure 48 Printer menu

B. On "System Config" menu, please press the [→] button indicated by red arrow.



Figure 49 Printer menu (System Config)

C. On "Network Config" menu, please press the [→] button indicated by red arrow.



Figure 50 Printer menu (Network Config)

D. On "Printer Config" menu, please press the [→] button indicated by red arrow.



Figure 51 Printer menu (Printer Config)

E. On "Operation" menu, please press the [Select] button indicated by red arrow.



Figure 52 Printer menu (Operation)

F. On "Print Sample" menu, please press the [Select] button indicated by red arrow.



Figure 53 Printer menu (Print Sample)

G. Please wait a while until sample card is printed as figure.

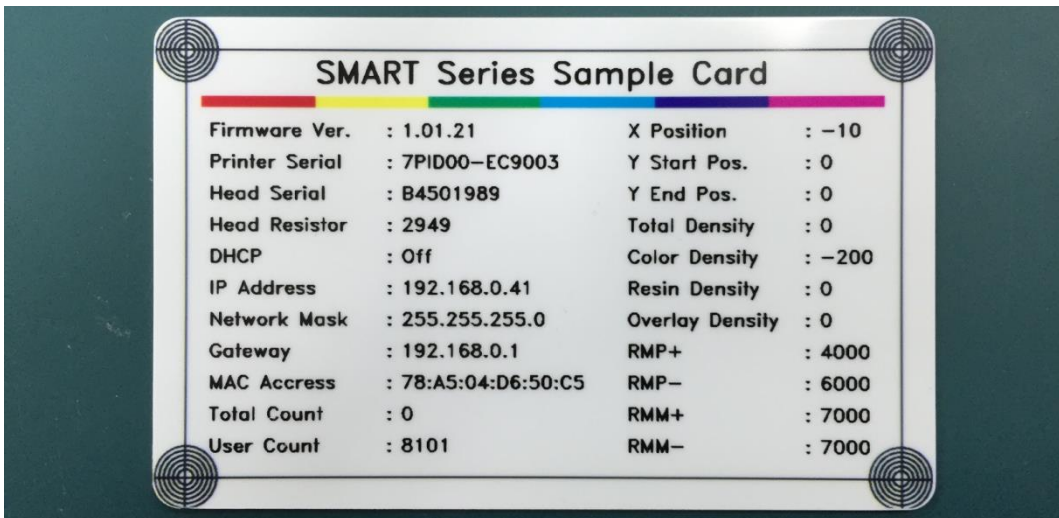

Figure 54 Sample Card

2.2 Advanced Hardware Installation

When more than one same module is installed on SMART-70 system or encoding option is installed into Hybrid Flipper, additional configuration is needed.

2.2.1 Module ID of SMART-70

Each module of SMART-70 has a specific ID to communicate with each other because a system of SMART-70 is combined by multiple modules. In that case, if a printer is combined in the system, the printer is a main agent of the communication, and if a printer is not combined in the system, a laminator is a main agent of the communication.

The main agent of communication should only be a Master. Thus, the first printer should be the Master and other printers should be the Slave when more than two printers are combined in a system, and the laminators combined in the system should also be the Slave. The default setting of SMART-70 Printer is the Master and SMART-70 Laminator is the Slave.

SMART-70 consists of Input Hopper(I), Printer(P), Laminator(L), Hybrid Flipper(H) and Output Hopper(O). One byte is used for the module ID, the high four bits are for the module type and the low four bits are for the module number. The module ID is as below.

Module	Default ID	ID Range
Input Hopper(I)	0x10	0x10 ~ 0x1F
Printer(P)	0x40	0x40 ~ 0x4F
Laminator(L)	0x50	0x50 ~ 0x5F
Hybrid Flipper(H)	0x60	0x60 ~ 0x6F
Output Hopper(O)	0x70	0x70 ~ 0x7F

When more than one same modules are combined in a system of SMART-70, the module ID should be adjusted for distinguishing each other of the same modules.

For example, in case of IPHPLHLO, the module ID should be adjusted as below because two printers, two Hybrid Flippers and two laminators are combined in a system of SMART-70.

Order of Modules	Module Name	Module ID
1	Input Hopper(I)	0x10
2	Printer(P0)	0x40
3	Hybrid Flipper(H0)	0x60
4	Printer(P1)	0x41
5	Laminator(L0)	0x50

6	Hybrid Flipper(H1)	0x61
7	Laminator(L1)	0x51
8	Output Hopper(O)	0x70

To adjust the module ID, the DIP switch on the main board of each module except Printer should be changed after removing the case. The DIP switch of each module is as below Figure 74.

SMART-70 Printer doesn't have the DIP switch, the module ID is automatically set to 0x40 when the Printer is the Master and the module ID is automatically set to 0x41 when the Printer is the Slave.

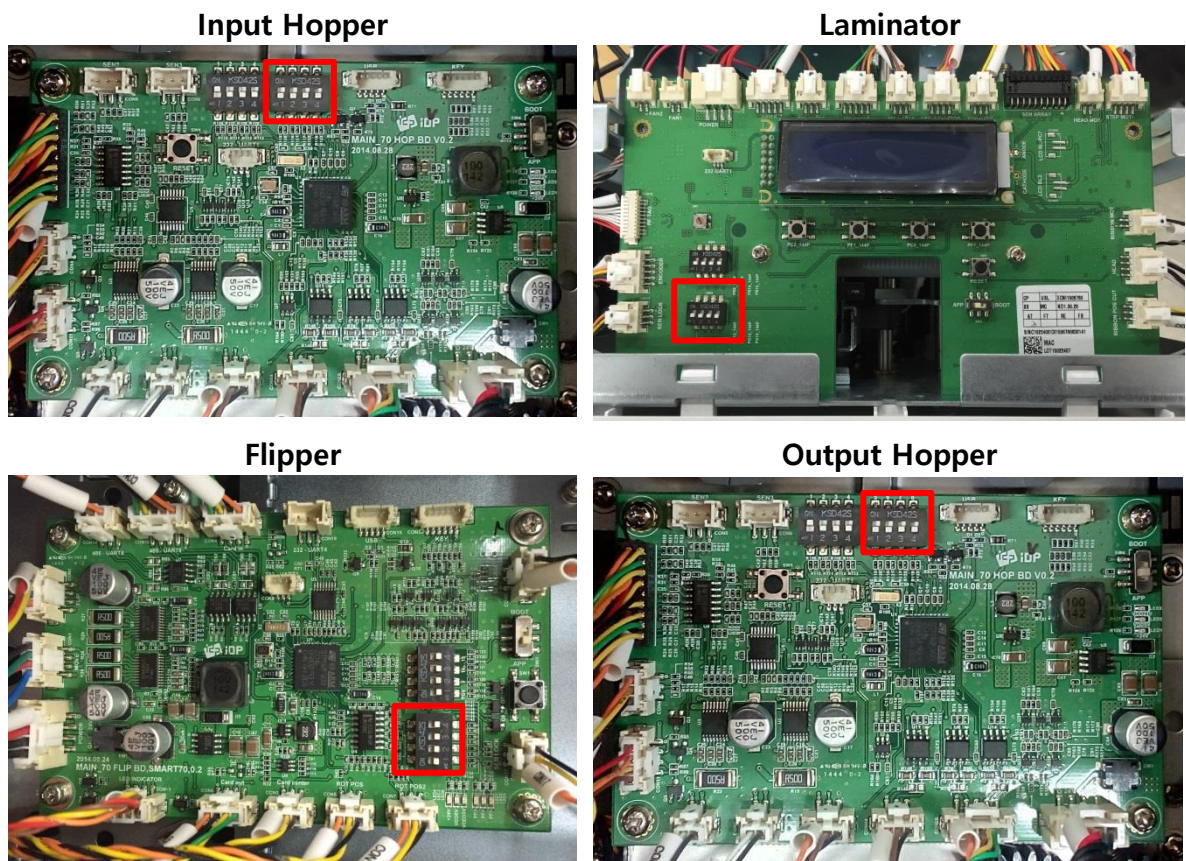

Figure 55 DIP switch location of SMART-70 module

The module type M is fixed as Input Hopper = 1 (0b1000), Laminator = 5 (0b1010), Hybrid Flipper 6 (0b0110) and Output Hopper 7 (0b1110). The module number is able to be adjusted as below.

DIP Switch	ID	DIP Switch	ID	DIP Switch	ID	DIP Switch	ID
	0xM0		0xM4		0xM8		0xMC

	0xM1		0xM5		0xM9		0xMD
	0xM2		0xM6		0xMA		0xME
	0xM3		0xM7		0xMB		0xMF

2.2.2 System configuration of SMART-70

SMART-70 is basically composed of the combination of Input Hopper(I), Printer(P), Laminator(L), Hybrid Flipper(H) and Output Hopper(O). The encoding option for the magnetic stripe card and contactless smartcard can be installed into the Printer. And, the encoding option for the contact and contactless smartcard and color image scanner can be installed into the Hybrid Flipper. Each encoding option is able to be recognized by USB Hub and Ethernet Board when the encoding options are installed into the Printer and the magnetic stripe card and contactless smartcard is able to be encoded by using SMART-70 SDK.

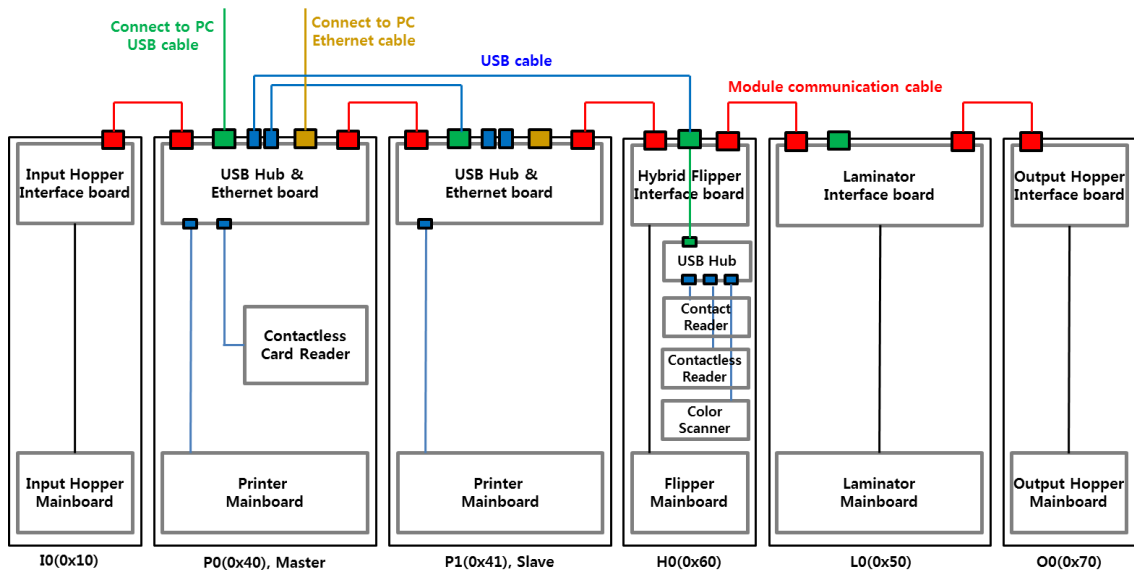

Figure 56 System configuration of SMART-70

In above Figure 77, contactless smartcard encoders are installed into the Printers of the IPPHLO combination. And, contact and contactless encoder and color image scanner is installed into the Hybrid Flipper of the IPPFLO combination. In that case, the modules should be connected and configured as below.

(1) Please adjust the module ID and Operation Mode as below.

- Input Hopper I0: Module ID = 0x10

- First printer P0: Module ID = 0x40, Operation Mode = Master
- Second Printer P1: Module ID = 0x41, Operation Mode = Slave
- Hybrid Flipper H0: Module ID = 0x60
- Laminator: Module ID = 0x50, Operation Mode = Slave
- Output Hopper O0: Module ID = 0x70.

(2) Please connect each module by using the red SATA cables

(3) Please connect the USB Host port of the first Printer P0 with the USB Device port of the second Printer P1 by using USB cable. Printing data is transmitted by the USB cable.

(4) Please connect the USB Host port of the first Printer P0 with the USB Device port of the Hybrid Flipper by using USB cable. Encoding and scanning data is transmitted by the USB cable.

(5) Please connect the USB Device port of the first Printer P0 to PC by using the USB cable or connect Ethernet port of the first Printer P0 to network.

(6) Please connect power adaptors to all modules and turn on the power switch on all modules.

(7) Please set the combination of the system as IPPHLO by using the LCD control panel on the first Printer.

2.2.3 Cable connection of SMART-70

RS485 is used for the inter-module communication of SMART-70 and SATA cable is used to connect each module. Red SATA cables are used to connect each module when SMART-70 Printer is installed as Figure 57.



Figure 57 Cable connection of SMART-70 IPHLO

When two Printers are combined in a system of SMART-70, the USB Host port of the first Printer should be connected to the USB Device port of the second Printer by using USB cable as Figure 58. When the Printers are connected as above method, the command to control the modules in the system is able to be transmitted via the red SATA cables and the printing data is able to be transmitted via the USB cable. The USB or Ethernet port of the first Printer is only able to be used for the communication with PC.

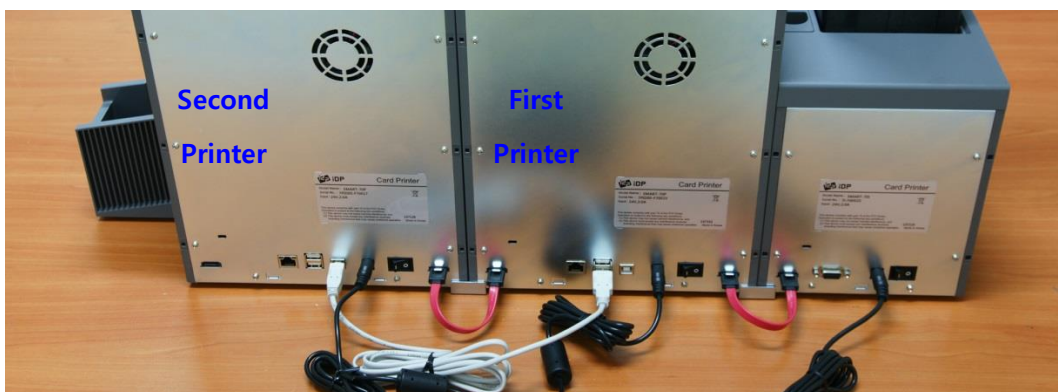

Figure 58 Cable connection of SMART-70 IPP

When encoding option or/and scanner is installed into the Hybrid Flipper, the USB Host port of Printer should be connected to the USB Device port of the Hybrid Flipper by using USB cable as

Figure 59. Encoding and scanning data is transmitted by the USB cable.

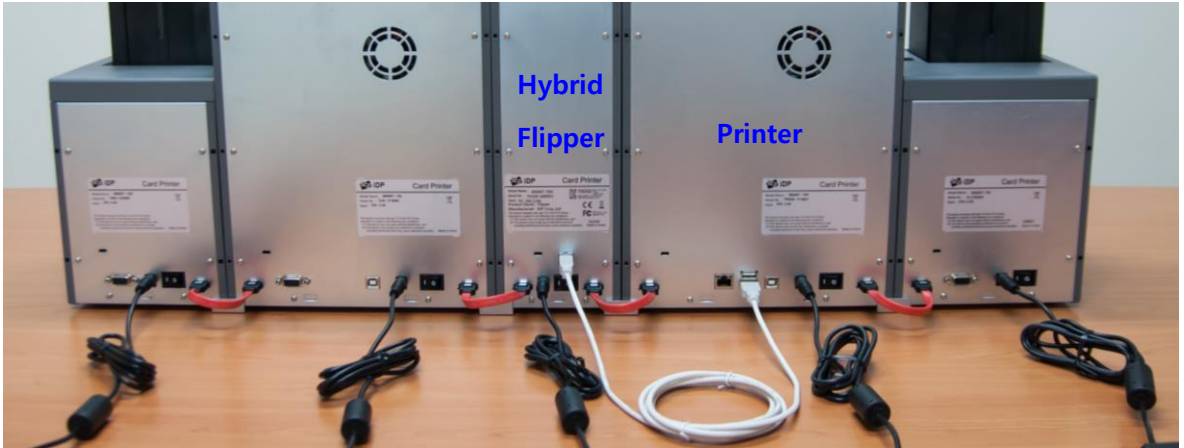

Figure 59 Cable connection of SMART-70 IPHLO

When two Printers are combined, and encoding or/and scanner option is installed into the Hybrid Flipper, the USB Host port of the first Printer should be connected to the USB Device port of the second Printer and the USB Host port of the first Printer should be connected to the USB Device port of the Hybrid Flipper as Figure 60.

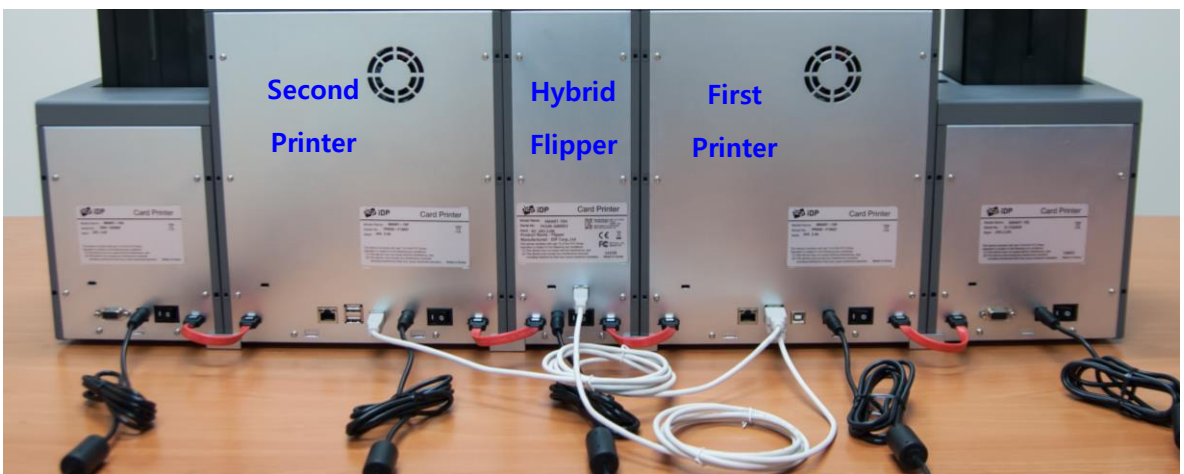

Figure 60 Cable connection of SMART-70 IPHPO

When SMART-70 system is first installed, the system combination of SMART-70 should be configured by using the LCD control panel.

2.3 Software installation (Windows Vista/7/8/10)



Figure 61 Printer driver installation 1

2.3.1 Start-up window

Please insert the installation CD provided with Printer and choose the language and click "Driver Install" button.

*) When you want to install printer driver for USB, please turn off Printer before installation. When you want to install printer driver for network, please turn on Printer.

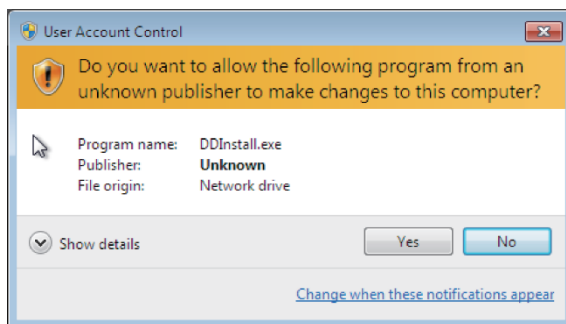

Figure 62 Printer driver installation 2

2.3.2 User Account Control

When "User Account Control" window is opened, please click "Yes"

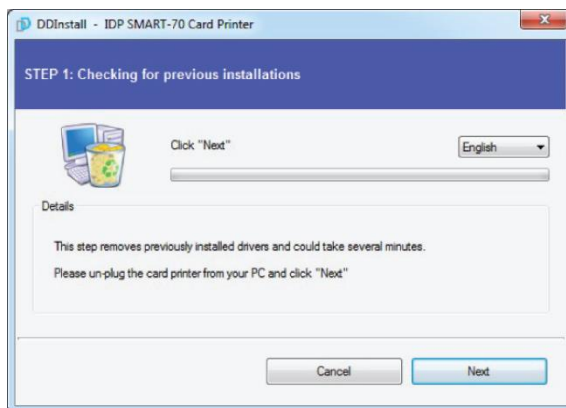

Figure 63 Printer driver installation 3

2.3.3 Driver Installation STEP 1

Please choose the language and click "Next". In STEP 1, previous installed printer driver is automatically checked and removed.

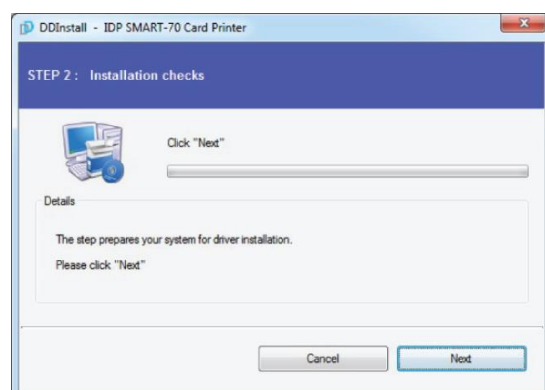

Figure 64 Printer driver installation 4

2.3.4 Driver Installation STEP 2-1

When "Next" is clicked, printer driver installation is prepared.

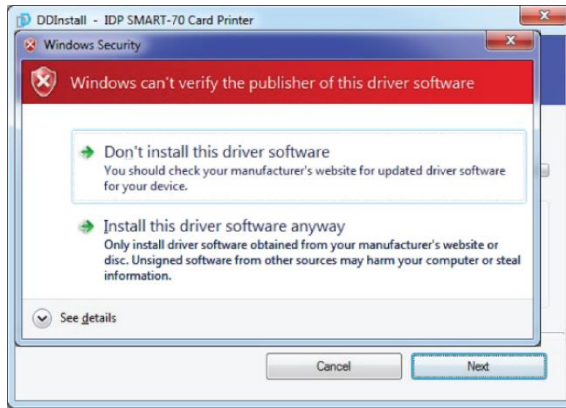

Figure 65 Printer driver installation 5

2.3.5 Driver Installation STEP 2-2

Please click "Install this driver software anyway" when Windows Security window comes up,

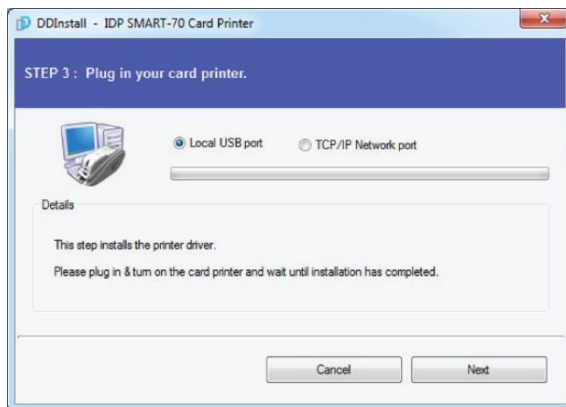

Figure 66 Printer driver installation 6

2.3.6 Driver Installation STEP 3-1

Please click "Next" when your Printer is connected via USB.

If you want to install the printer driver for network, please select the "TCP/IP Network port" and select a proper Printer as shown in the next step (2.3.7).

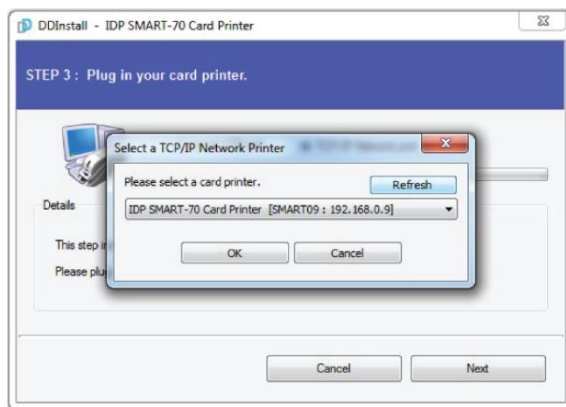

Figure 67 Printer driver installation 7

2.3.7 Driver Installation STEP 3-2

Please select a proper Printer on the list and click "OK".

(If Printer is not on the list of the network printer select window, Printer is not connected to network. So, please check the status of network connection.)



Figure 68 Printer driver installation 8

2.3.8 USB port connection

Please connect USB cable to Printer.

(If your Printer is connected to network, please check the status of network connection.)

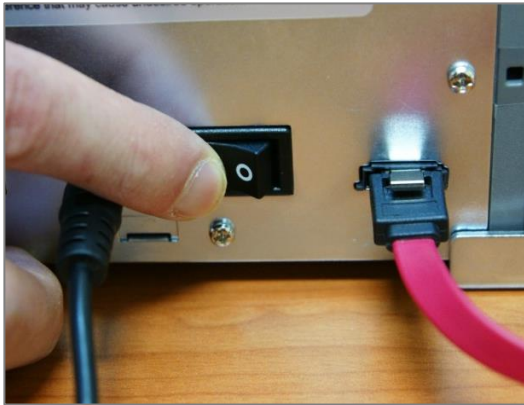

Figure 69 Printer driver installation 9

2.3.9 Power on

Please turn on all the modules.

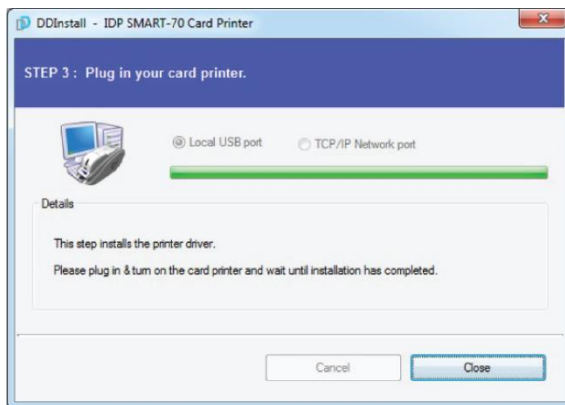

Figure 70 Printer driver installation 10

2.3.10

Driver installation completion

Printer driver installation is completed after turning on Printer. When driver installation is completed, please click "Close".

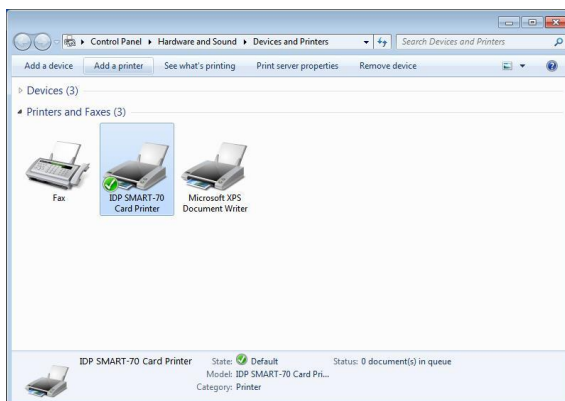

Figure 71 Printer driver installation 11

2.3.11 Driver installation check 1

Please open "Devices and Printers" window and check that "IDP SMART-70 Card Printer" is created properly.

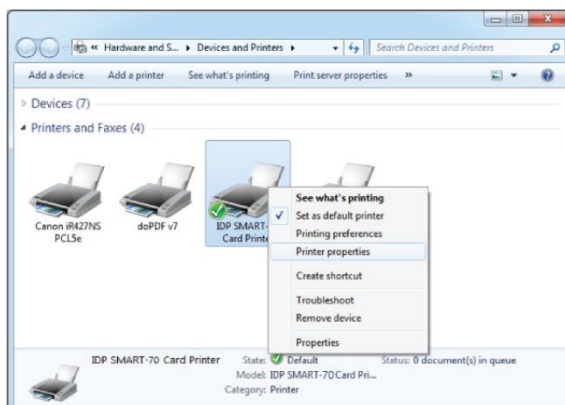

Figure 72 Printer driver installation 12

2.3.12 Driver installation check 2

Please right click on "IDP SMART-70 Card Printer" and select "Printer Properties"

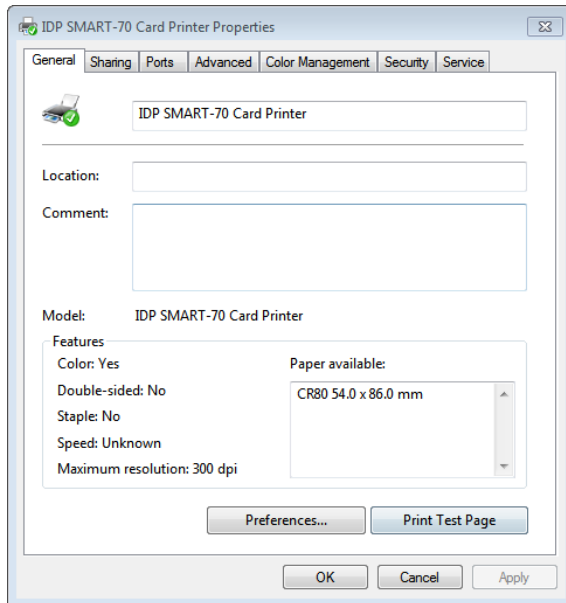

Figure 73 Printer driver installation 13

2.3.13 Driver installation check 3

Please select the "General" tab on "IDP SMART-70 Card Printer" properties and click "Print Test Page".



Figure 74 Printer driver installation 14

2.3.14 Driver installation check 4

When test page is being printed, the window for checking printing status comes up. After checking printed test card, if the test card is properly printed, please click "Close".



Figure 75 Application installation 1

2.3.15 Application installation 1

After printer driver installation, please install SMART Design and DB by clicking "Install Smart Application".

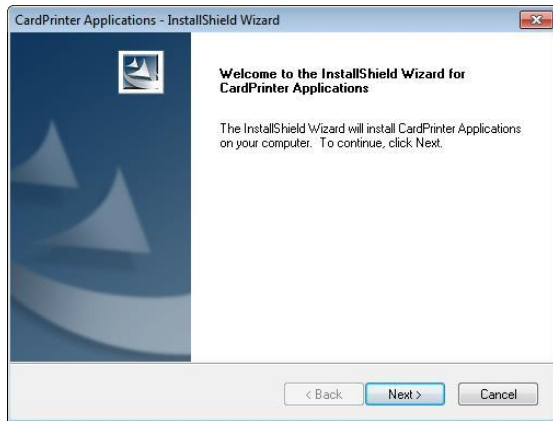

Figure 76 Application installation 2

2.3.16 Application installation 2

When "Smart Application Install ShieldWizard" window is opened, please click "Next".

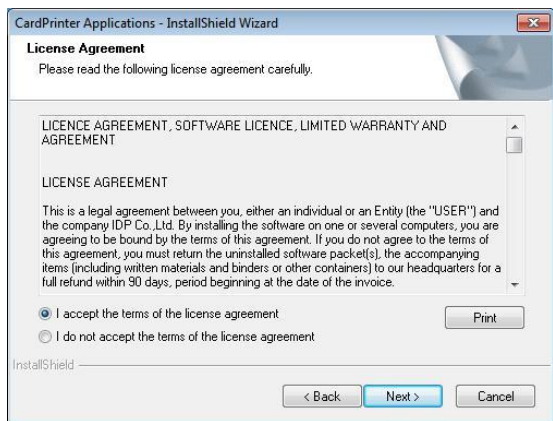

Figure 77 Application installation 3

2.3.17 Application installation 3

Please choose "I accept the terms of the license agreement" and click "Next".

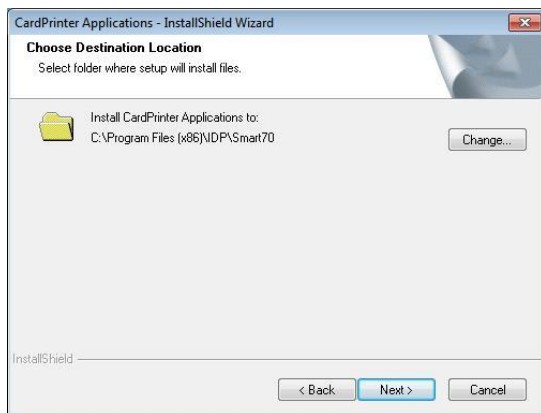

Figure 78 Application installation 4

2.3.18 Application installation 4

Please select destination location for application installation and click "Next"

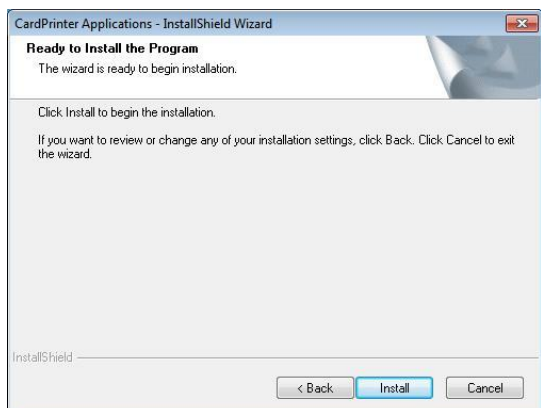

Figure 79 Application installation 5

2.3.19 Application installation 5

Please click "Install".

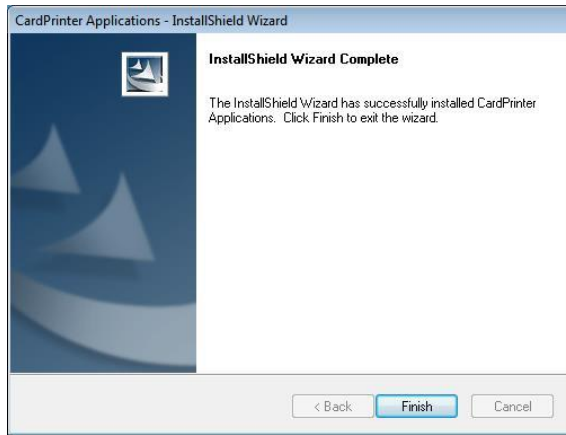

Figure 80 Application installation 6

2.3.20 Application installation 6

After the application installation is completed, please click "Finish" and use the installed application.

3. Driver configuration

SMART-70 Printer can print cards by selecting various required properties. To adjust printer properties, please open the Devices and Printers window and right click on "IDP SMART-70 Card Printer" and select "Printer Properties".

3.1 Printing preferences

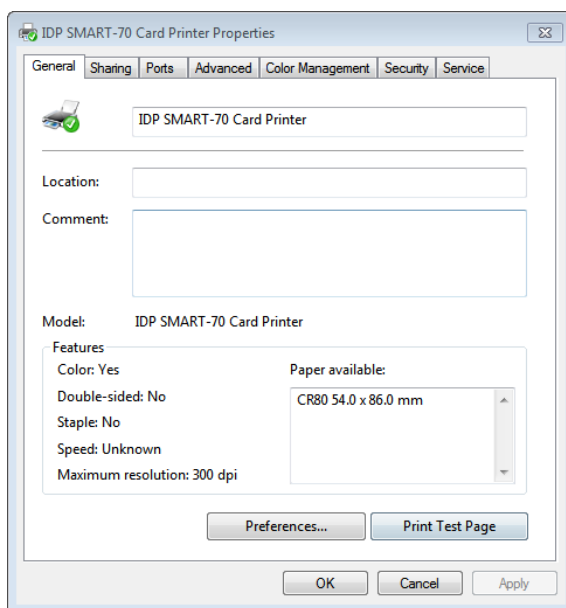

Figure 81 Printer properties window

3.1.1 Printing Preferences

Please click "Printing Preferences" on the "General" tab of Printer Properties window.

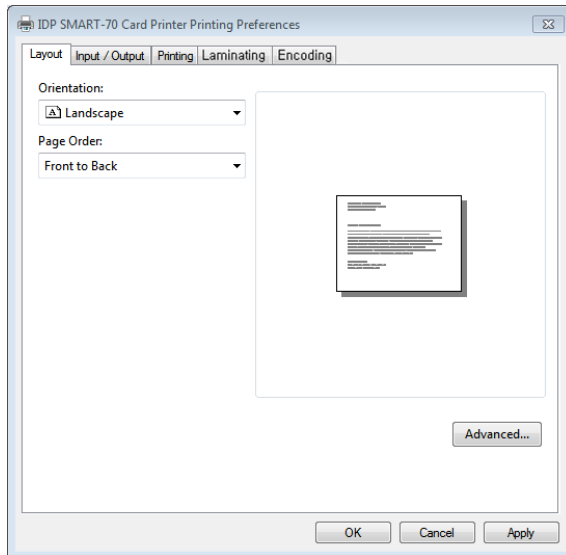

Figure 82 Layout

3.1.2 Layout

The print orientation (Landscape or Portrait) can be selected.

To apply your selection, please click "OK".

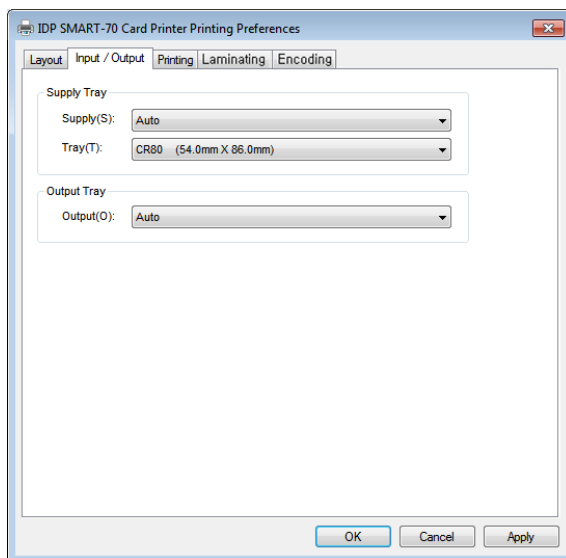

Figure 83 Input / Output settings

3.1.3 Input / Output settings

Supply Tray

Supply: If there is one Input Hopper, please select "Auto". If there are multiple Input Hoppers, please select the Hopper which will be used.

Tray: Please select "CR80" because SMART-70 only supports CR80 cards.

Output Tray

Output: If there is one Output Hopper select "Auto". If there are multiple Output Hoppers, please select the Hopper which will be used.

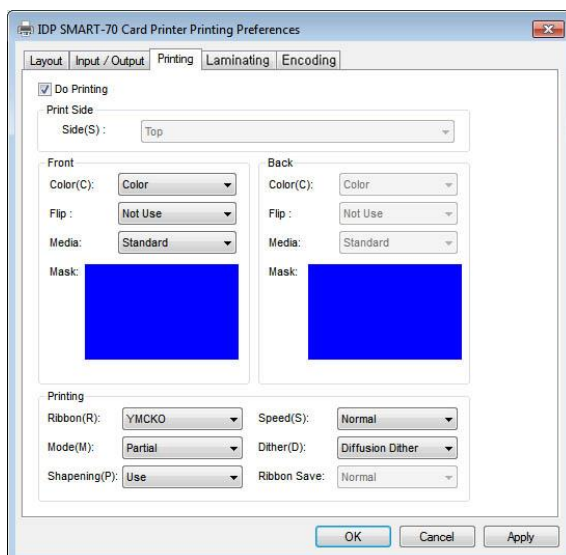

3.1.4 Printing settings

Do Printing: To set whether print or not.

Print Side: To set the single sided or dual sided printing when Hybrid Flipper is installed.

Front / Back

Color: To set the color or mono printing.

Flip: To turn the printed image on card.

Mask: To set the printing area on card. The

User defined mask uses BITMAP file (1012 x 636 pixels).

Blue(RGB(0,0,255)) : Print and Overlay

Light blue(RGB(0,255,255)) : Overlay only

Pink(RGB(255,0,255)) : Print only

Yellow(RGB(255,255,0)) : Florescent only

Figure 84 Printing settings

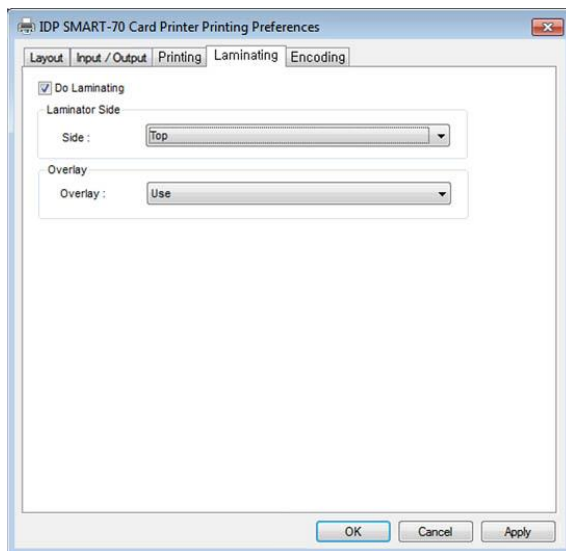

Figure 85 Laminating settings

predefined masks (normal card, smartcard, magnetic stripe card, etc.) or user defined mask can be used.

Printing

Ribbon: The print ribbon type is used for printing and can be automatically recognized.

Speed: To set the printing speed.

Mode: To set the all or partial printing.

Dither: Set the dithering types.

Sharpening: To calibrate the printed image sharpness.

Ribbon Save: To set that the card is printed by using the split function when the mono ribbon is used.

3.1.5 Laminating settings

This tab will be created only when SMART-70 Laminator module is connected.

Do Laminating: To set whether laminate or not.

Laminator Side: To set the laminating side of card (top, bottom and both sides).

Overlay: To set whether overlay panel is printed or not. Default is no overlay when the card is laminated. We recommend no overlay when the card is laminated.

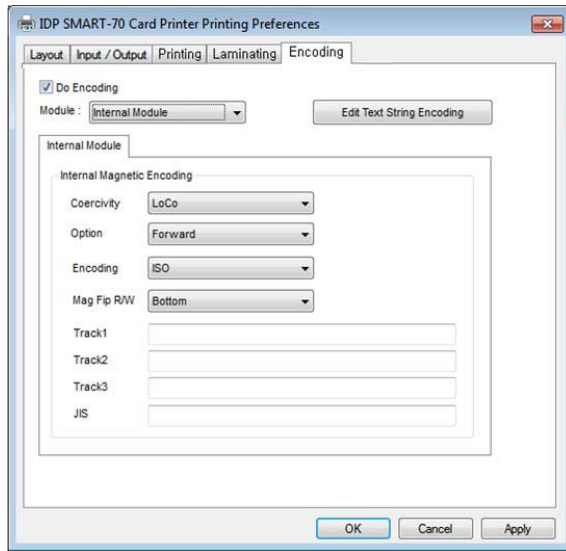

3.1.6 Encoding settings

This tab will be created only when SMART-70 Magnetic Encoding option is installed.

Do Encoding: To set whether encoding or not.

Module: To set whether the internal module (Printer) or the external module (Hybrid Flipper) is used.

Coercivity: To set the type of the magnetic stripe cards for encoding.

LoCo: 300, 600 Oe.

HiCo: 2760 Oe.

SpCo: 4000 Oe.

Auto: Automatic encoding depending on a used magnetic stripe card type.

Option: To set the encoding direction (Forward / Backward / Bitmode).

Encoding: To set the encoding protocol (ISO / Bally's).

Mag Flip R/W: To set the encoding side of magnetic stripe card.

Figure 86 Encoding settings

3.2 Advanced setup

For Advanced setup, please click the "Advanced" button on "Printing Preferences" window and you can adjust the advanced setting.

- **Reset Default Values:** Advanced setting is reset to the default values.
- **Color Correction:** Adjusting gamma value of each color panel can change color sense. The higher gamma value is the darker color. The absolute printing density can be adjusted by

using "**CardPrinter70Setup**" utility.

- **Main [-100:100]:** To adjust the gamma values of all panels.
- **Yellow [-100:100]:** To adjust the gamma value of the yellow panel.
- **Magenta [-100:100]:** To adjust the gamma value of the magenta panel.
- **Cyan [-100:100]:** To adjust the gamma value of the cyan panel.
- **Black [-100:100]:** To adjust the gamma value of the resin black panel.
- **Overlay [-100:100]:** To adjust the gamma value of the overlay panel.
- **Position Processing:** The printing position between panels can be adjusted. If the value is higher, the positions are more accurate but the color sense may be a little lower.
 - **Color [-32:32]:** To adjust the printing position of the color panels (yellow, magenta and cyan).
 - **Mono [-32:32]:** To adjust the printing position of the resin black panel.
 - **Overlay [-32:32]:** To adjust the printing position of the overlay panel.
- **Resin Black (K) Processing:** The method to extract the data to be printed by the resin black is specified.
 - **Text [0:100]:** To set the density criteria for extracting the text to be printed by the resin black.
 - **Dot [0:100]:** To set density criteria for extracting the pixels to be printed by the resin black.
 - **Threshold [0:100]:** To set density criteria for printing by the resin black when the dithering is performed by using the Threshold.
 - **Dithering Degree [0:100]:** To set sharpness when the dithering is performed by using the Random.
 - **Resin Extraction:** Method to extract the data for the resin black.
 - > **Black object:** Text, line, etc. Black objects are extracted.
 - > **Black Text:** Text is only extracted.
 - > **Black Dots:** All black dots are extracted.
 - > **Not Use:** No extraction.
- **Rewritable Controls:** This property is only for rewritable printer.

- **Erase Density [0:100]:** To set the temperature to erase the contents on rewritable card.
- **Wait Option:** This option can set the card's waiting time at each encoding position when the smart card is encoded without using SDK. One contactless smart card encoder can be installed into SMART-70 Printer.
When this option is set and the SDK is not used for encoding, the program which the smart card is recognized and encoded within the specified waiting time must be developed by yourself because the card is only waiting for a specified time at the encoding position.
- **Wait at Internal Module Contactless Encoding Position [On/Off]:** To set that the contactless smart card is waiting at the contactless smart card encoding position in Printer.
 - > **Card Side [Front/Back]:** To set the direction of card when the card is waiting.
 - > **Wait Position [-100:100]:** To adjust the card position from the previous waiting position of card to the left or the right (unit is 0.1mm).
- > **Wait Time [0:1000]:** To set the waiting time of card (unit is a second).

3.3 Other settings

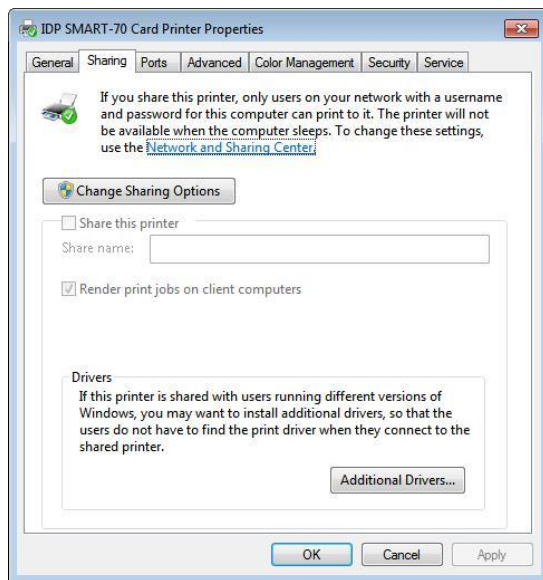

Figure 87 Printer sharing settings

3.3.1 Sharing

Printer can be shared via network by setting the option of printer sharing on the Sharing tab.

Default is "Not sharing".

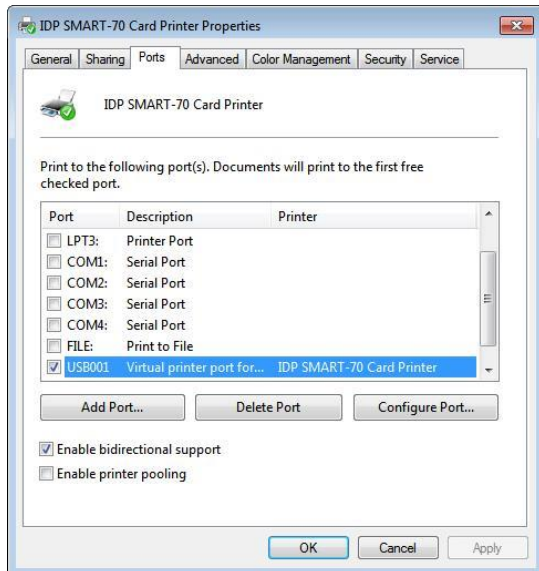

Figure 88 Ports setting

3.3.2 Ports

The Port tab shows which port is connected to SMART-70 Printer. On Figure, USB001 Virtual printer port is connected because SMART-70 Printer was connected via USB.

(Caution! The adjustment on the ports setting by user is not recommended because the port is automatically set.)

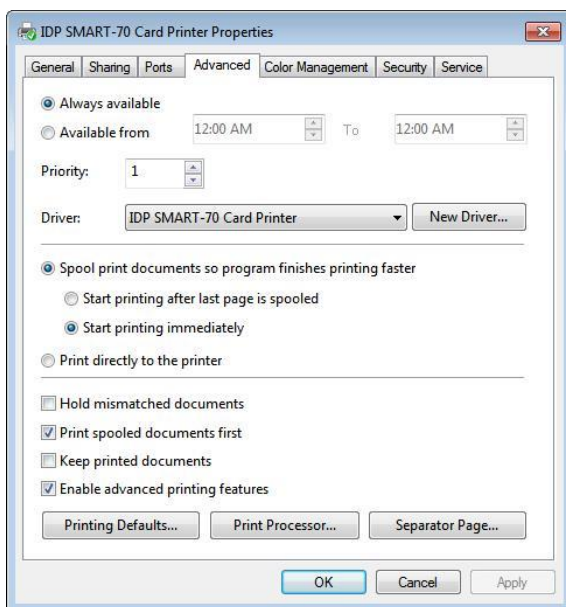

Figure 89 Advanced settings

3.3.3 Advanced

The working time, priority order, spool and etc. can be set in "Advanced" tab. The Advanced setting follows MS Windows standard. If you want to change the setting, please refer to the MS Windows manual.

(No adjustment on the Advanced setting is recommended.)

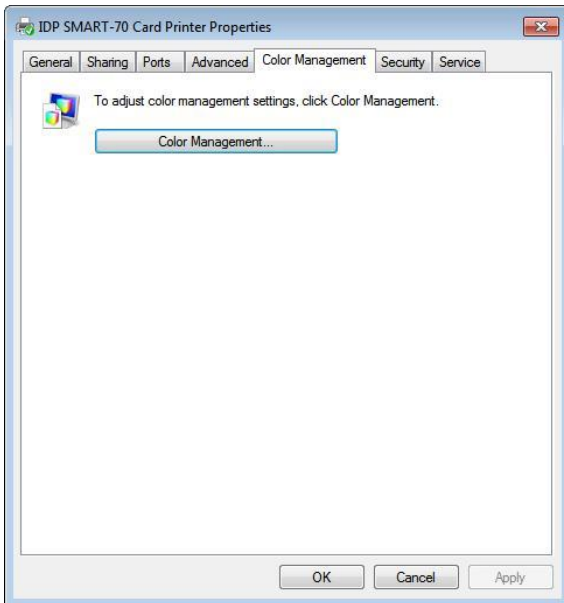

Figure 90 Color Management settings

3.3.4 Color Management

The proper color profile for Printer can be set on the Color Management tab. For supporting the optimized color printing, SMART-70 Printer can automatically set the color profile depending on the ribbon type loaded in Printer because the ribbon type is automatically recognized.

(No adjustment on the Color Management setting is recommended.)

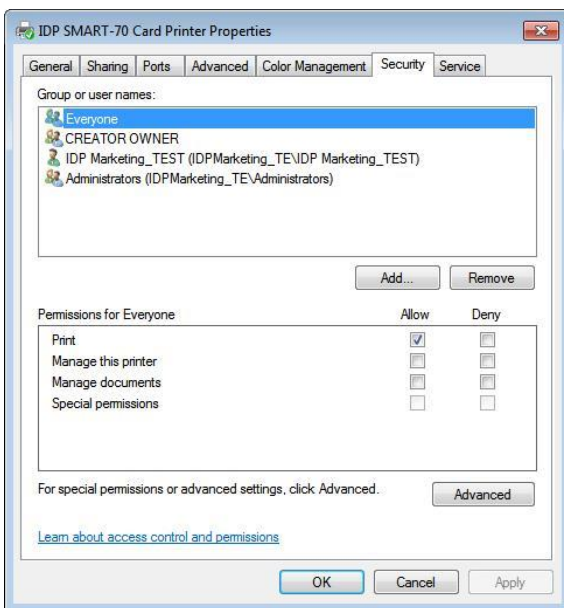
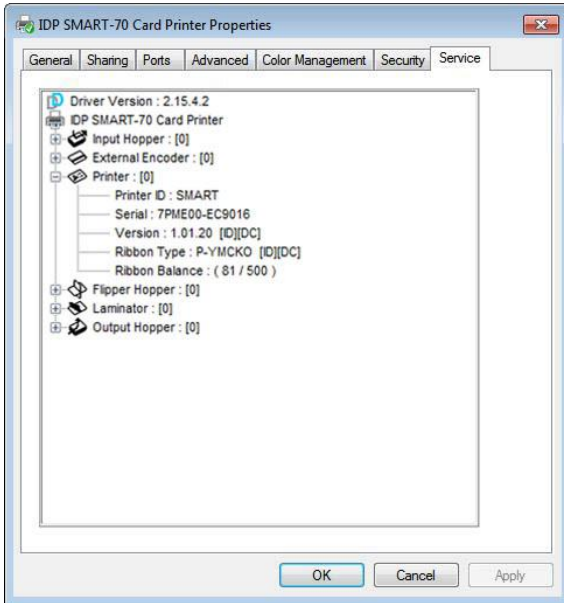

Figure 91 Security setting

3.3.5 Security

The access control and permissions for Printer can be set. According to the authority, the printing, management and special authority can be permitted.



3.3.6 Printer status check

The serial number, ID, driver version, firmware version, ribbon type and balance of all connected modules can be checked on the Service tab.

Figure 92 Printer status check

4. SMART-70 Utilities

The installation CD of SMART-70 Printer includes utilities for printer setting, test and firmware upgrade. This chapter explains the SMART-70 utilities.

4.1 Printer setting

SMART-70 Printer is manufactured and shipped with optimized setting on each one. By the way, printer setting can be adjusted by using CardPrinter70Setup utility included in the Installation CD after disassemble and assemble of printer, replacement of some parts or when the adjustment of printer setting is needed. Printer setting can be adjusted by using CardPrinter70Setup as below.

4.1.1 CardPrinter70Setup

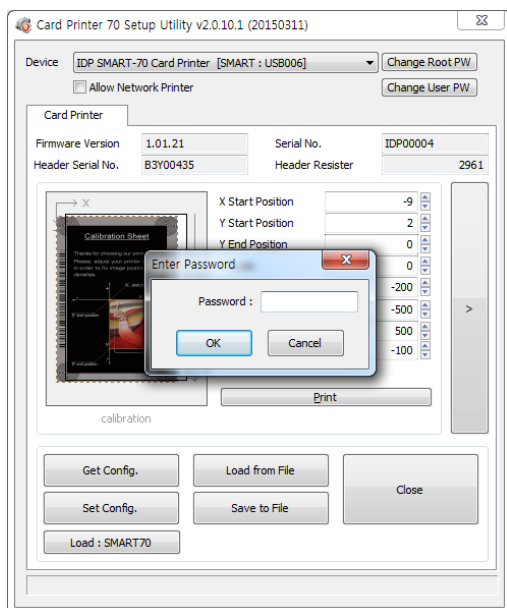

Password input window is displayed when you run this program. If the correct password is inputted, the recorded setup values in SMART-70 Printer are shown and the setup values can be adjusted.

The password for SMART-70 Printer is saved to the SMART-70 Printer. When the SMART-70 Printer is connected to another PC, the saved password in the SMART-70 Printer is required to run this utility and adjust the Printer setting.

(When password has never been set, please click "OK" because there is no default password in SMART-70 Printer.)

Figure 93 CardPrinter70Setup Log-in

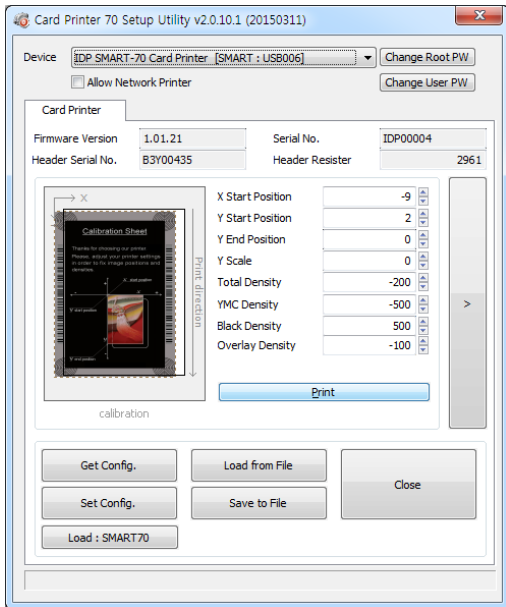

When you are successful to login, the basic setup of Printer is shown as Figure 94.

Figure 94 CardPrinter70Setup Start

4.1.2 Basic Setup

The basic setup of CardPrinter70Setup shows the firmware version, serial number and etc. of the connected SMART-70 Printer, frequently used setting values (printing position, density and etc.) can be adjusted.

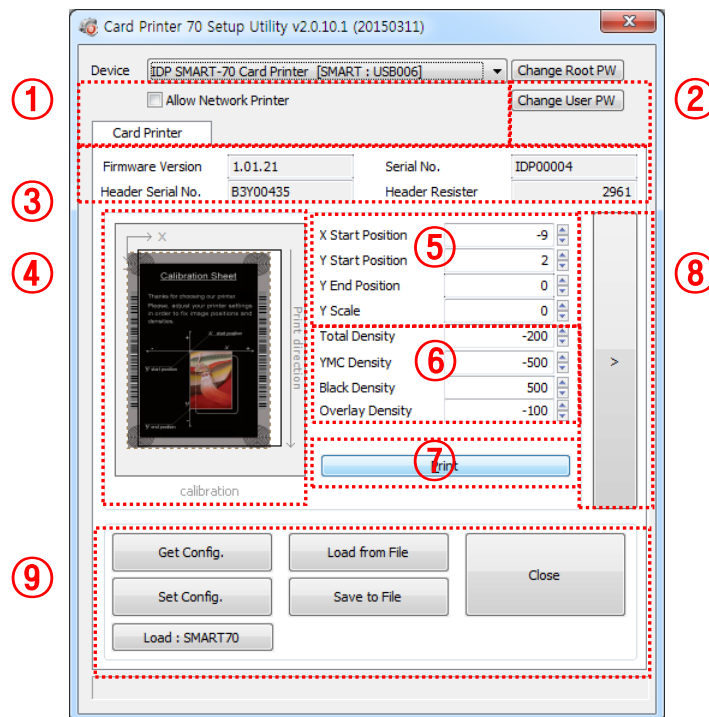

Figure 95 Basic Setup of CardPrinter70Setup

- ① To show connected Printer.

Device: The Printer that the adjustment is needed can be selected by using the pull-down menu. "IDP SMART-70 Card Printer" is the connected Printer's name. "SMART" is the connected Printer's ID, "USB006" is the connected port.

Allow Network Printer: If the Allow Network Card Printer is selected, Printers connected via network also appear in the "Device" list.

- ② To set administrator password and user password.

Change Root PW: To set administrator (root) password. This password is used to verify user authority for CardPrinter70Setup and is also required as administrator password when the User Authentication option on Security is set on advanced setup.

(When Printer is installed at the place where security is required, please set password at the same time with the installation of Printer.)

Change User PW: To set user password for user authentication. This password is required as user password when the User Authentication option on Security is set on advanced setup.

- ③ The firmware version, serial number of Printer, serial number of TPH, resistance value of TPH, type of TPH is shown.

- ④ The printing area on card is shown. It shows exaggeratingly for user convenience and is not real position.

- ⑤ To set the printing area on card. Please set it properly to print on an entire card because SMART-70 is a direct thermal card printer. When you click "⑦ Print", a card is printed as like "④ example". Please set values properly that all circles of each corner are printed and blank spaces are narrower than 0.5mm on the top and the bottom of a card. Please set values by following order.

X Start Position: Please set the right and the left of printing position on card properly by adjusting X position.

Y Start Position: Please set the start position of printed example image and blank space in the top is 0.4mm ~ 0.5mm.

Y End Position: Please set the end position of printed example image and blank space in the bottom is 0.4mm ~ 0.5mm. It is recommended to set bigger value for "Y scale" than default.

Y Scale: Please set to print all circles in the bottom of card.

- ⑥ To set printed density. SMART-70 enables to set different density for each color, resin black and overlay. So, proper setting on each density is needed for high quality. Please optimize the quality by adjusting each value. To optimize, you repeatedly adjust the density and print a Calibration card by using color ribbon and clicking "⑦ Print", and please check the printed state until you get the optimum.

Total Density: To set all of the density (Color, Black and Overlay) at one time.

YMC Density: To set color density. Please maximize YMC density as you can, which enables to extend range of color and to print vivid images. If it is too strong, green or red marks are appeared as Figure 93. If it is too weak, the print quality will be dull.



Figure 96 Color density

Black Density: To Set resin black density. In the picture, barcode is printed by resin black. When density is too strong, barcode is printed too thick. When density is too weak, barcode is too thin. Please adjust resin black density to print clear barcode. Please refer following pictures.

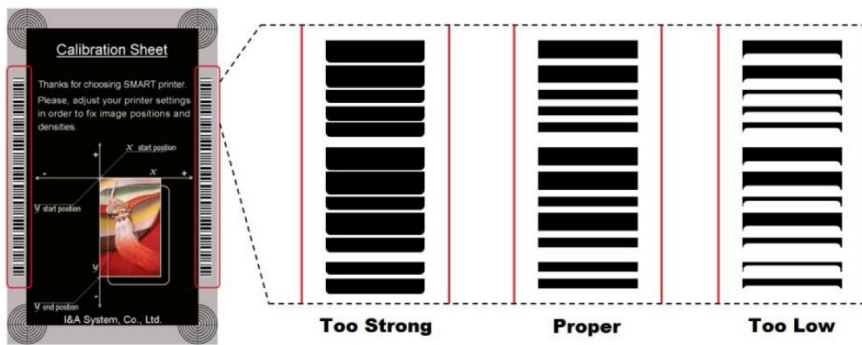

Figure 97 Resin Black density

Overlay Density: To set overlay density. Please adjust it until overlay is printed on surface regularly. If it is too strong, it is hazy and marks are appeared. If it is too weak, overlay panel is not printed edge areas. You can check it with printed card under the light.

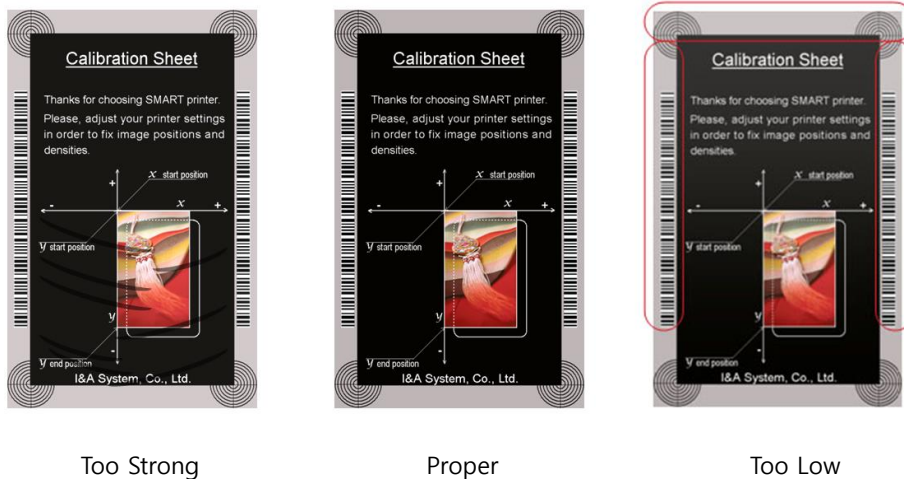

Figure 98 Overlay density

⑦ To print calibration card for adjusting the printing position and density.

⑧ To show advanced setup.

(The advanced setup for expert options is not recommended to adjust.)

⑨ To load or save the setup values.

Get Config.: To get values from current connected Printer.

Set Config.: To set values to current connected Printer.

Load from File: To load setup values from file.

Save to File: To save setup values to file.

Load Default: To reset setup values to default. After loading default, all setup values must be adjusted again. Load Default is not recommended.

Close: To close CardPrinter70Setup.

4.1.3 Advanced Setup

Expert setup of SMART-70 Printer can be adjusted on advance setup. If you are unsure, please contact your dealer.

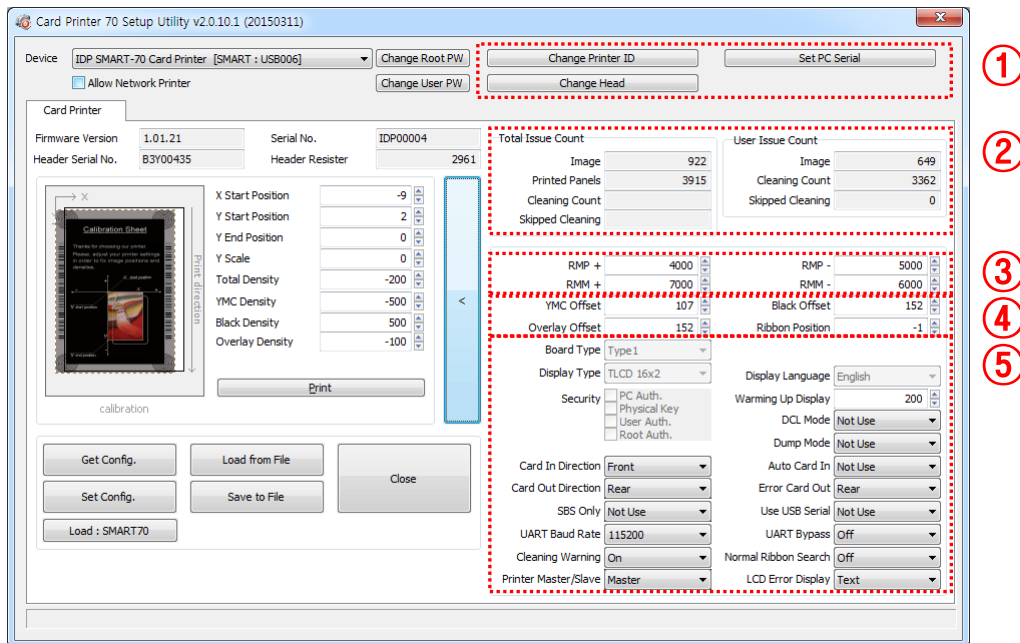

Figure 99 Advanced Setup

- ① To set Printer ID, PC Serial and Print Head register after replacing.

Change Printer ID: When SMART-70 is used by SDK, unique ID for SMART-70 Printer is set regardless of whether it is connected via USB or what IP address is. It is useful to connect and use several Printers. Factory default is "SMART".

Set PC Serial: One of security functions. This function can be only used when Printer is connected via USB and the Printer can be used with a specific PC. It is activated when "Set PC Serial" is clicked after "PC Authentication" of ⑤ Security is set and rebooted. At that time, the specific information of connected PC is saved to SMART-70 Printer and the saved information is used to authenticate the connected PC.

Change Header: When thermal print head is replaced, the print head information must be registered for optimal printing quality. Please change print head's serial number, resistance value and type in the Change Head Dialog window after click "Change Head".

To show how many cards are issued with SMART-70 Printer. "Total Issue Count" is the number of issued cards after factory shipment. "User Issue Count" is the number of issued cards after replacing print head. When the print head is replaced, please initialize the number by setting "Reset User Issue Count" in the Change Head Dialog window after clicking "Change Head" of ①.

- ② SMART-70 Printer controls motor for the best printing quality. "RMP+", "RMP-", "RMM+" and "RMM-" is necessary variables to control ribbon motor. Please do not adjust the variables because the printing quality is affected.

When the normal printing speed is set, "YMC Offset", "Black Offset" and "Overlay Offset" is added to the YMC Density, Black Density and Overlay Density and printed on card. "Ribbon Position" is to align the panel of ribbon on the card. Please use the default setting.

- ③ Please refer as below for other values.

Board Type: To set the mainboard type of SMART-70 Printer. Please do not change.

Display Type: To set the LCD type of SMART-70 Printer. Please do not change.

Display Language: To select the display language on the LCD of SMART-70 Printer. Please do not change.

Security: SMART-70 Printer provides several ways to set a security function for authentication and access control.

PC Auth.: Printer can only be used with specific PC. To activate this option, "Set PC Serial" is clicked to save the specific PC's information into Printer.

Physical Key: When physical key is installed into SMART-70, this option can set to activate Printer by using the key.

User/Root Authentication: This option can set to activate Printer by using User and Administrator (Root) password.

DCL Mode: When SDK is used to print cards with DCL mode, printer driver doesn't need to be installed. If the DCL mode is set to "Use", printer driver is not installed on Windows.

Dump Mode: Log data can be recorded into Printer.

Card In Direction: To set the direction that card is fed.

Auto Card In: When the card is detected at card gate, the card is automatically moved into Printer.

Card Out Direction: To set the direction that card is ejected.

Error Card Out: To set the direction which error card (encoding failed card) is ejected.

SBS Only: This option is only activated when SDK is used to print card. Printer driver can't be used when this option is set.

Use USB Serial: When SMART-70 Printer is connected to USB, Printer transmits the USB serial number to PC. Default is the same number used by all SMART-70. **To connect multiple SMART-70 Printers to only one PC via USB, Please set this option to "USE" for using unique serial numbers for each Printer.**

UART Baud Rate: To set the communication speed (Baud rate) of the external device connected to Printer by serial.

UART Bypass: When Printer is communicated with an external device by serial interface, the commands are passed without any processing.

Cleaning Warning: After a certain number of printings, Printer is contaminated and needed to clean for keeping the Printer in the best condition. If cleaning is required, please set how to display the warning message.

Normal Ribbon Search: To set that SMART-70 can search the panel of ribbon more accurately in ribbon searching.

Printer Master/Slave: SMART-70 Printer can variously be configured according to your needs and two Printers can be connected and used. In this case, this option is used to set the Printer connected to PC via USB to "MASTER" and set the other Printer to "SLAVE".

LCD Error Display: To set the displayed message type on the LCD of Printer when error occurs in Printer.

4.2 Printer test

Since card printer basically use standard printer device driver, card can be printed by the same method as a general paper printer. By the way, if encoding options are installed into card printer, appropriate device driver for each encoding option must be installed and each encoding option must be properly operated. In this case, encoding options can be controlled by "Card Printer SDK". CardPrinter70Test utility is to test the functions of SMART-70 Printer and is developed by "SMART-70 Printer SDK".

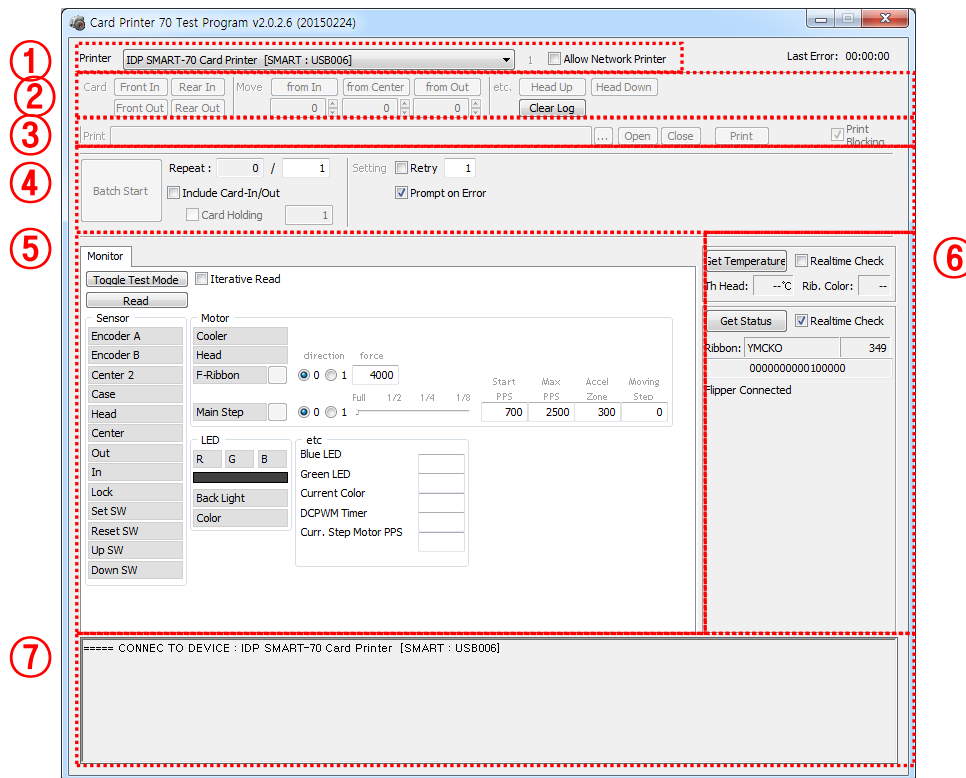

Figure 100 ardPrinter70Test

- ① **Select Printer:** To select a Printer for test. In the picture. "IDP SMART-70 Card Printer" is the connected Printer's name, "SMART" is the connected Printer's ID and "USB006" is the connected port.
- ② **Basic Control:** To execute basic functions of Printer (Card In/Out, Print Head Up/Down, etc.).
- ③ **Print:** To print a CSD file which is designed by SMART Design.
- ④ **Batch Job:** To execute the job of ⑤ repeatedly.
- ⑤ **Monitor:** To check the working status of sensors and motors.
- ⑥ **Printer Status:** To check the status of Printer.

⑦ **Message:** To display messages when this utility is run.

4.2.1 Printer selection and basic control

When CardPrinter70Test is run, Printers connected via USB are automatically searched and can be selected by priority. After setting "Allow Network Printer", all Printers connected via USB and network can be selected. Other Printer can be selected by using pull-down menu. When a printer is connected to this utility, the basic control, print and monitor can be tested.

The basic control functions will be provided later.

4.2.2 Print Test

Print is to print a CSD file designed by SMART Design. This function will be provided later.

4.2.3 Batch Job

Batch job is to test the status of encoding and decoding continuously. This function will be provided later.

4.2.4 Monitor

Monitor is to check the status of Printer in the "Monitor" tab.

Toggle Test Mode: To switch between normal mode and board test mode.

Read: To read the status of sensors and motors from Printer.

Iterative Read: When the "Iterative Read" is set, the status of sensors and motors is periodically read from Printer.

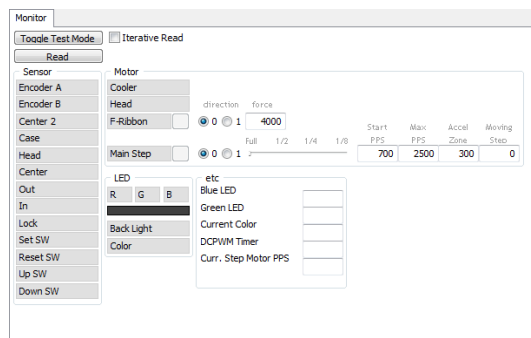

Figure 101 Monitor

4.2.5 Printer status

“**Get Temperature**” is to get and display the temperature of Thermal Print Head. When the “Realtime Check” is set, the temperature of Thermal Print Head is got and displayed in real time.

“**Get Status**” is to get and display the status of Printer.

Status Codes are as below.

#define	S7PS_M_SBSRUNNING	0x0000000000000001// SBS (Step by Step) command execution
#define	S7PS_M_CARDMOVE	0x0000000000000002// Move to print
#define	S7PS_M_CARDIN	0x0000000000000004// Card In
#define	S7PS_M_CARDOUT	0x0000000000000008// Card Out
#define	S7PS_M_THEAD	0x0000000000000010// Thermal Head Up/Down
#define	S7PS_M_SEEKRIBBON	0x0000000000000020// Ribbon Search
#define	S7PS_M_MOVERIBBON	0x0000000000000040// Ribbon Move
#define	S7PS_M_PRINT	0x0000000000000080// Printing
#define	S7PS_M_MAGRW	0x0000000000000100// Magnetic Read/Write
#define	S7PS_M_RECVPRIINTDATA	0x0000000000000200// Printing data Receiving
#define	S7PS_M_INIT	0x0000000000000400// Initializing
#define	S7PS_S_INSTALLINTENCODER	0x0000000000008000// Internal Encoder Installed
#define	S7PS_S_INSTALLEXTHOPPER	0x0000000000010000// External Input Hopper Installed
#define	S7PS_S_INSTALLEXTSTACKER	0x0000000000020000// External Output Hopper Installed
#define	S7PS_S_INSTALLEXTENCODER	0x0000000000040000// External Encoder Installed
#define	S7PS_S_INSTALLEXTLAMINATOR	0x0000000000080000// External Laminator Installed
#define	S7PS_S_INSTALLEXTFLIPPER	0x0000000000100000// External Hybrid Flipper Installed
#define	S7PS_S_INSTALLEXTETC	0x0000000000200000// External Other Device Installed
#define	S7PS_S_CASEOPEN	0x0000000000400000// Case Open
#define	S7PS_S_SOFTLOCKED	0x0000000000800000// Soft Locked
#define	S7PS_S_KEYLOCKED	0x0000000001000000// Key Locked
#define	S7PS_S_DETECTCARD	0x0000000002000000// Card Detected Internal Sensor
#define	S7PS_S_DETECTFRONTDEVICE	0x0000000004000000// Front Device Detected
#define	S7PS_S_DETECTREARDEVICE	0x0000000008000000// Rear Device Detected

```

#define S7PS_S_CLEANWARNING      0x0000000010000000// Printer Cleaning Warning
#define S7PS_S_HAVEPRINTDATA     0x0000000020000000// Have Printing Data
#define S7PS_S_SBSMODE           0x0000000040000000// SBS Mode
#define S7PS_S_TESTMODE         0x0000000080000000// Test Mode

```

Error Codes are as below.

```

#define S7PS_E_CARDIN           0x0000000100000000// Card In Error
#define S7PS_E_CARDMOVE        0x0000000200000000// Card Move Error
#define S7PS_E_CARDOUT         0x0000000400000000// Card Out Error
#define S7PS_E_THEADLIFT       0x0000000800000000// Thermal Head Up/Down Error
#define S7PS_E_PRINT           0x0000004000000000// Printing Error
#define S7PS_E_MAGRW           0x0000008000000000// (Internal) Magnetic Read/Write Error
#define S7PS_E_MAGREADT1       0x0000010000000000// (Internal) Mag. Track 1 Read Error
#define S7PS_E_MAGREADT2       0x0000020000000000// (Internal) Mag. Track 2 Read Error
#define S7PS_E_MAGREADT3       0x0000040000000000// (Internal) Mag. Track 3 Read Error
#define S7PS_E_CONNECTEXTHOPPER 0x0000080000000000// External Hopper Connection Error
#define S7PS_E_CONNECTEXTSTACKER 0x0000100000000000// External Stacker Connection Error
#define S7PS_E_CONNECTEXTENCODER 0x0000200000000000// External Encoder Connection Error
#define S7PS_E_CONNECTEXTLAMINATOR 0x0000400000000000// External Laminator Connection Error
#define S7PS_E_CONNECTEXTFLIPPER 0x0000800000000000// External Hybrid Flipper Connection Error
#define S7PS_E_CONNECTEXTETC    0x0001000000000000// External Other Device Connection Error
#define S7PS_E_EXTPRESETMATCH   0x0002000000000000// External Preset Device Connection Error
#define S7PS_E_RIBBONSEEK       0x0080000000000000// Ribbon Search Error
#define S7PS_E_RIBBONMOVE       0x0100000000000000// Ribbon Move Error
#define S7PS_F_THEADABSENT      0x0200000000000000// Uninstalled Thermal Head
#define S7PS_F_THEADOVERHEAT    0x0400000000000000// Overheat Thermal Head
#define S7PS_F_RIBBONABSENT     0x0800000000000000// No Ribbon
#define S7PS_F_PRINTDATA        0x1000000000000000// Printing Data Error
#define S7PS_F_INCORRECTPASSWORD 0x2000000000000000// Incorrect Password
#define S7PS_F_CONFIG           0x4000000000000000// Configuration Fail

```

4.3 Firmware upgrade

SMART-70 Modules' firmware can be updated by using CardPrinter70Firmware. Since SMART-70 is operated by combined several modules, firmware of each module can be individually upgraded as necessary.

When CardPrinter70Firmware is run, the window as below is shown.

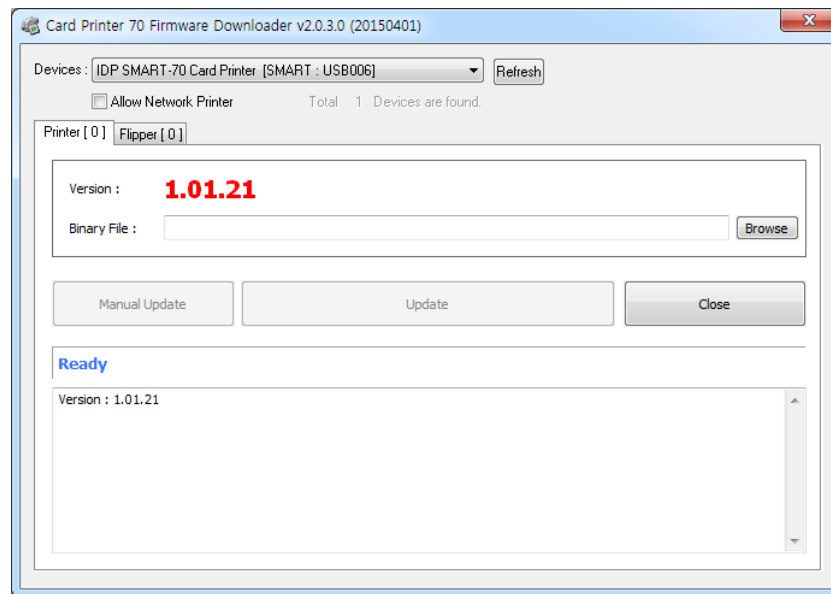

Figure 102 CardPrinter70Firmware

Devices: To select the Printer that firmware will be upgraded.

Allow Network Printer: To set that Printers connected via network are displayed in Devices.

Printer [0] / ... : To select the modules of SMART-70 system that firmware is upgraded.

Version: To displays the current firmware version of selected Printer.

Binary File: To select the new firmware file. Please click "Browse" button to search and select the new firmware file.

Manual Update: To upgrade the firmware manually.

Update: To upgrade the firmware automatically. Update for automatic upgrading is generally recommended.

Close: To close this utility.

Message: Necessary information is displayed when the firmware is being upgraded.

4.3.1 Printer connection

After SMART-70 Printer is connected to PC and the connected Printer is selected on Devices of CardPrinter70Firmware, all modules of SMART-70 System are displayed as tabs. SMART-70 System is combined by "Printer module 0" and "Hybrid Flipper module 0" as Figure 103.

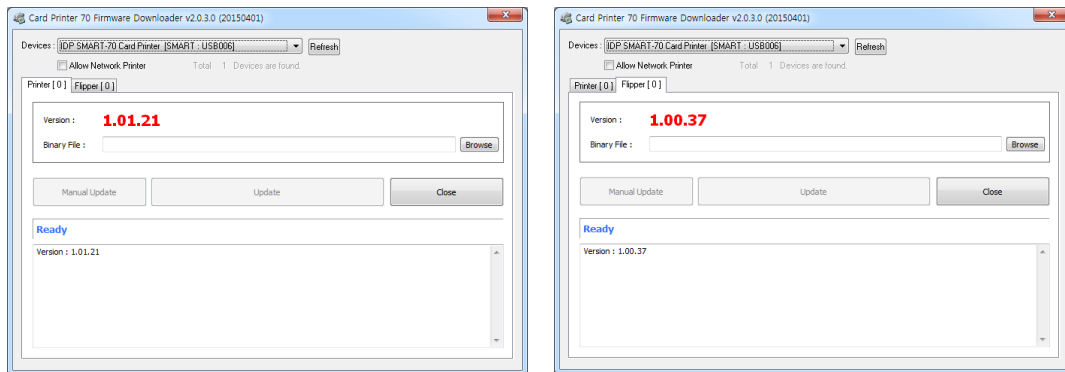

Figure 103 Modules of SMART-70 System (Printer, Hybrid Flipper)

4.3.2 Module Firmware Upgrade

After clicking the tab of the combined modules of SMART-70 System such as "Printer [0]" or Hybrid Flipper [0]", please click "Browse" and search and select the new firmware for the module. After selecting the new firmware, "Manual Update" and "Update" is activated. Please click "Update" for automatic firmware upgrade, and the Printer is automatically rebooted after firmware upgrade.

(Caution. Please do not do another job until the firmware upgrade is successfully completed and do not turn off the Printer.)

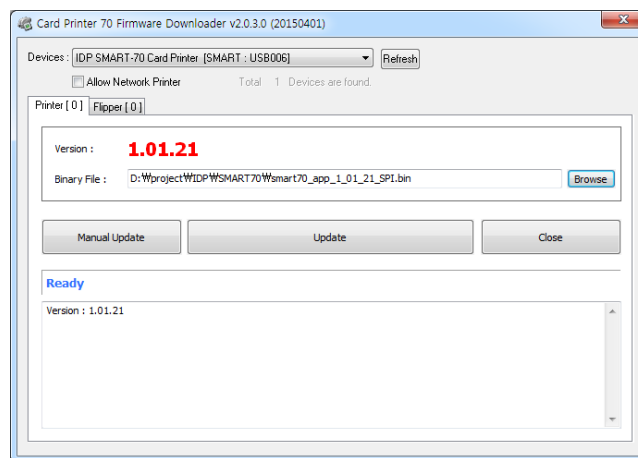

Figure 104 Ready for firmware upgrade

In case there is some problems in automatic firmware upgrade, please click "Manual Update" to manually upgrade firmware. According to the pop-up window as below figure, firmware can manually be upgraded by clicking "Transfer" after the Printer is manually turned on and off.

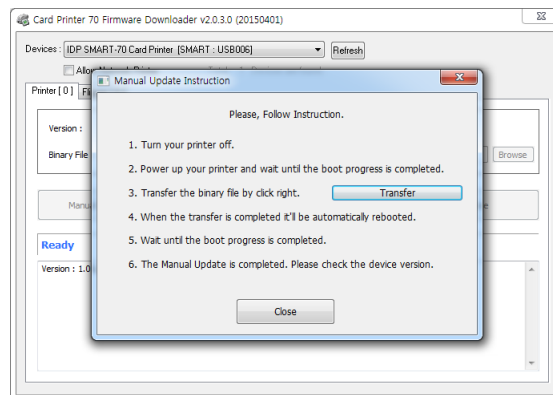

Figure 105 Manual firmware upgrade

5. Troubleshooting

5.1 Printing quality

5.1.1 Unprinted or wrong colors printed spot

- **The card surface is contaminated by foreign substance :**
After checking the status of card, please change it to another clean card.
- **The cleaning roller is contaminated :**
After checking the cleaning roller. If the cleaning roller is contaminated too much, please change a disposable cleaning roller.
- **Dust is too much in printer :**
Please clean the inside of printer by using cleaning kit.

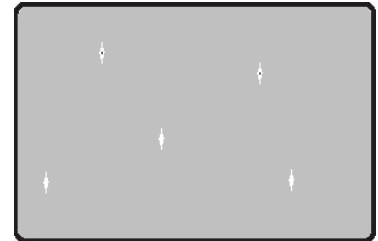

Figure 106 Printing quality trouble 1

5.1.2 Unprinted horizontal line

- **The print head is contaminated by foreign substance :**
Please clean the print head by using cleaning kit.
- **The print head is damaged :**
Please contact the local supplier to replace the print head.
- **The ribbon cartridge is improperly installed :**
Please check the installation status of ribbon cartridge and whether the print ribbon has wrinkles.



Figure 107 Printing quality trouble 2

5.1.3 Blurry or unstable print

- **Uneven or bad surface of card :**
Please change cards.
- **Too high or too low setting of color density :**
The printing density of your printer must be adjusted. Please contact the local supplier.
- **The print head is contaminated by foreign substance :**
Please clean the print head by using cleaning kit.



Figure 108 Printing quality trouble 3

5.1.4 Not aligned color print

- **Non-standard or bad cards :**
Please change cards
(ISO CR80 card (54mm x 86mm) must be used).
- **Uneven or bad surface of card :**
Please change cards.
- **Card feeding or printing roller is contaminated :**
Please clean the rollers by using cleaning kit
- **Outdated printer :**
Please contact the local supplier.

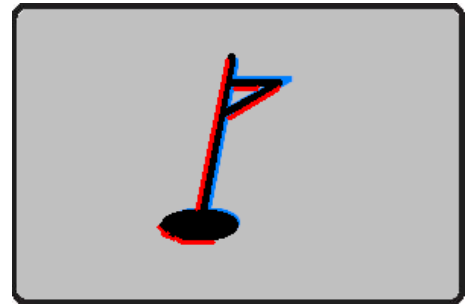

Figure 109 Printing quality trouble 4

5.1.5 Unplanned color print

- **Non-standard or bad cards :**
Please change cards
(ISO CR80 card (54mm x 86mm) must be used).
- **Card feeding or printing roller is contaminated :**
Please clean the rollers by using cleaning kit
- **Malfunctioned ribbon sensors :**
Please contact the local supplier to replace the sensors.
- **Outdated printer :**
Please contact the local supplier.



Figure 110 Printing quality trouble 5

5.2 Card supply

5.2.1 Card is not supplied or 2 cards are supplied from Input Hopper

- **Non-standard or bad cards :**
Please change cards
(ISO CR80 card (54mm x 86mm) must be used).
- **Card cartridge is improperly loaded :**
Please properly load the card cartridge into Input Hopper again.
- **Card thickness of card cartridge is improperly set :**
Please properly adjust the card thickness control lever depending on the thickness of card. In case card is not supplied, please adjust the lever to the right.
In case 2 cards are supplied, please adjust the lever to the left.



Figure 111 Card supply problem 1

5.3 Card jam

5.3.1 Card jam in Input Hopper



Figure 112 Card jam in Input Hopper 1

A. Card jam in Input Hopper 1

Please separate Input Hopper as Figure after disconnecting power adaptor and communication cable at rear side.



Figure 113 Card jam in Input Hopper 2

B. Card jam in Input Hopper 2

If card is jammed on the card gate of Input Hopper as Figure, please remove the jammed card by pulling out.



Figure 114 Card jam in Input Hopper 3

C. Card jam in Input Hopper 3

If card is not on the card gate of Input Hopper but card cartridge can't be pulled up, please push in and pull out a new card as Figure.

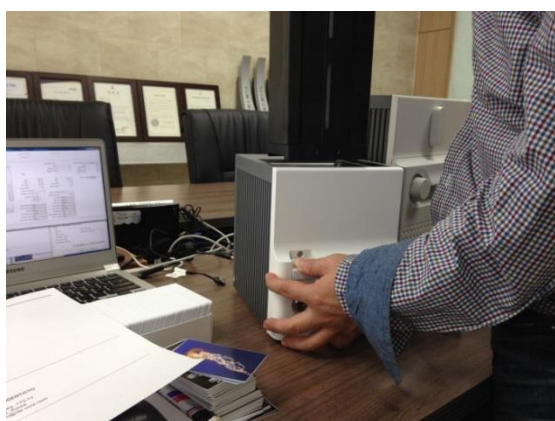

Figure 115 Card jam in Input Hopper 4

D. Card jam in Input Hopper 4

Please pull up card cartridge while pushing the cartridge release button as Figure.



Figure 116 Card jam in Input Hopper 5

E. Card jam in Input Hopper 5

If card is jammed at the gate of card cartridge as Figure, please remove the jammed card by pulling out.

5.3.2 Card jam in Printer



Figure 117 Card jam in Printer 1

A. Card jam in Printer 1

Please turn the ribbon cartridge lock lever to the clockwise 90 degrees as Figure.



Figure 118 Card jam in Printer 2

B. Card jam in Printer 2

Please pull out the ribbon cartridge as Figure.



Figure 119 Card jam in Printer 3

C. Card jam in Printer 3

If print ribbon is stuck to card or coiled on rollers as Figure, the ribbon cartridge may not be pulled out easily. In this case, please cut the ribbon or slowly pull out the ribbon cartridge while pressing the "←" or "→" button on the control panel of Printer little by little.



Figure 120 Card jam in Printer 4

D. Card jam in Printer 4

To remove a jammed card in Printer, please press the "→" button on the control panel of Printer until the jammed card is completely ejected.



Figure 121 Card jam in Printer 5

E. Card jam in Printer 5

If print ribbon is cut, please stick the cut ribbon together by using a sticky tape and then turn the dial on ribbon cartridge until unused panel of ribbon is on take-up core.

5.3.3 Card jam in Hybrid Flipper

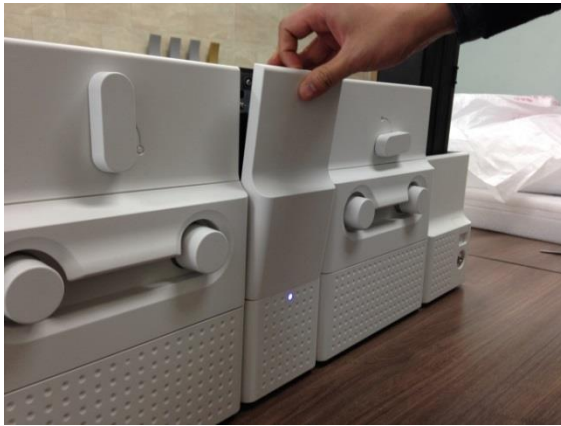

Figure 122 Card jam in Hybrid Flipper 1

A. Card jam in Hybrid Flipper 1

Please open the cover of Hybrid Flipper by pulling as Figure.



Figure 123 Card jam in Hybrid Flipper 2

B. Card jam in Hybrid Flipper 2

Please pull out the error card bin in Hybrid Flipper as Figure.



Figure 124 Card jam in Hybrid Flipper 3

C. Card jam in Hybrid Flipper 3

To remove a jammed card, please turn the rotating tray of Hybrid Flipper until the vertical by hand as Figure.



Figure 125 Card jam in Hybrid Flipper 4

D. Card jam in Hybrid Flipper 4

Please pull out a jammed card as Figure.

5.3.4 Card jam in Laminator



Figure 126 Card jam in Laminator 1

A. Card jam in Laminator 1

Please turn the film cartridge lock lever to the clockwise 90 degrees as Figure.



Figure 127 Card jam in Laminator 2

B. Card jam in Laminator 2

Please pull out the film cartridge as Figure.

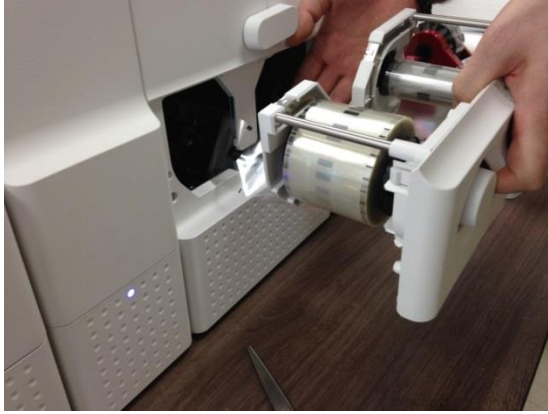

Figure 128 Card jam in Laminator 3

C. Card jam in the Laminator 3

If laminating film is stuck to card or coiled on rollers as Figure, the film cartridge may not be pulled out easily. In this case, please cut the laminating film or slowly pull out the film cartridge while pressing the "←" or "→" button on the control panel of Laminator little by little.



Figure 129 Card jam in Laminator 4

D. Card jam in Laminator 4

To remove a jammed card in laminator, please press the "→" button on the control panel of Laminator until the jammed card is completely ejected.



Figure 130 Card jam in Laminator 5

E. Card jam in Laminator 5

If laminating film is cut, please stick the cut laminating film together by using a sticky tape and then turn the dial on film cartridge until unused laminating film is on take-up core.

5.3.5 Card jam in Output Hopper



Figure 131 Card jam in Output Hopper 1

A. Card jam in Output Hopper 1

Please separate Output Hopper as Figure after disconnecting power adaptor and communication cable at rear side.



Figure 132 Card jam in Output Hopper 2

B. Card jam in Output Hopper 2

If card is jammed on the card gate of Output Hopper as Figure, please remove the jammed card by pulling out.



Figure 133 Card jam in Output Hopper 3

C. Card jam in Output Hopper 3

If card is not on the card gate of Output Hopper but card cartridge can't be pulled up, please push in and pull out a new card as Figure.



Figure 134 Card jam in Output Hopper 4

D. Card jam in Output Hopper 4

Please pull up card cartridge while pushing the cartridge release button as Figure.



Figure 135 Card jam in Output Hopper 5

E. Card jam in Output Hopper 5

If card is jammed at the gate of card cartridge as Figure, please remove the jammed card by pulling out.

5.4 Cleaning

5.4.1 Input Hopper cleaning



Figure 136 Input Hopper cleaning 1

A. Input Hopper cleaning 1

Please separate Input Hopper as Figure after disconnecting power adaptor and communication cable at rear side.



Figure 137 Input Hopper cleaning 2

B. Input Hopper cleaning 2

Please remove the disposable cleaning roller holder in Input Hopper as Figure.

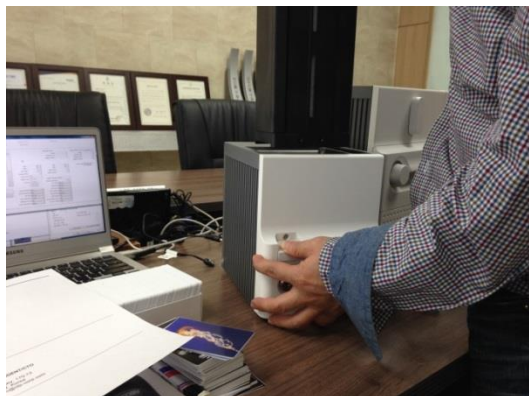

Figure 138 Input Hopper cleaning 3

C. Input Hopper cleaning 3

Please pull up the card cartridge while pushing the cartridge release button as Figure.



Figure 139 Input Hopper cleaning 4

D. Input Hopper cleaning 4

Please push a cleaning card into the card gate of Input Hopper as Figure and clean rollers by pushing in and pulling out the cleaning card slowly and repeatedly.

5.4.2 Printer cleaning



Figure 140 Printer cleaning 1

A. Printer cleaning 1

Please turn the ribbon cartridge lock lever to the clockwise 90 degrees as Figure.



Figure 141 Printer cleaning 2

B. Printer cleaning 2

Please pull out the ribbon cartridge as Figure.



Figure 142 Printer cleaning 3

C. Printer cleaning 3

Please push a cleaning card in Printer while pressing the "→" button on the control panel of Printer for 30 seconds as Figure.

After cleaning, please press the "←" button to remove the cleaning card.

5.4.3 Hybrid Flipper cleaning



Figure 143 Hybrid Flipper cleaning 1

A. Hybrid Flipper cleaning 1

Please separate Hybrid Flipper as Figure after disconnecting power adaptor and communication cable at rear side.



Figure 144 Hybrid Flipper cleaning 2

B. Hybrid Flipper cleaning 2

Please push a cleaning card into the card gate of Hybrid Flipper until the cleaning card is shown at the other side as Figure and clean rollers by pushing in and pulling out the cleaning card slowly and repeatedly.

5.4.4 Laminator cleaning



Figure 145 Laminator cleaning 1

A. Laminator cleaning 1

Please turn the film cartridge lock lever to the clockwise 90 degrees as Figure.



Figure 146 Laminator cleaning 2

B. Laminator cleaning 2

Please pull out the film cartridge as Figure.



Figure 147 Laminator cleaning 3

C. Laminator cleaning 3

Please push a cleaning card in Laminator while pressing the "→" button on the control panel of Laminator for 30 seconds as Figure. After cleaning, please press the "←" button to remove the cleaning card.

5.4.5 Output Hopper cleaning



Figure 148 Output Hopper cleaning 1

A. Output Hopper cleaning 1

Please separate Output Hopper as Figure after disconnecting power adaptor and communication cable at rear side.



Figure 149 Output Hopper cleaning 2

B. Output Hopper cleaning 2

Please pull up the card cartridge while pushing the cartridge release button as Figure.



Figure 150 Output Hopper cleaning 3

C. Output Hopper cleaning 3

Please push a cleaning card into the card gate of Output Hopper as Figure and clean rollers by pushing in and pulling out the cleaning card slowly and repeatedly.

5.5 TPH (Thermal Print Head) replacement



Figure 151 TPH replacement 1

A. TPH replacement 1

Please turn the ribbon cartridge lock lever of Printer to the clockwise 90 degrees as Figure.



Figure 152 TPH replacement 2

B. TPH replacement 2

Please pull out the ribbon cartridge as Figure.



Figure 153 TPH replacement 3

C. TPH replacement 3

Please detach the print head while pressing the print head detaching button as Figure.

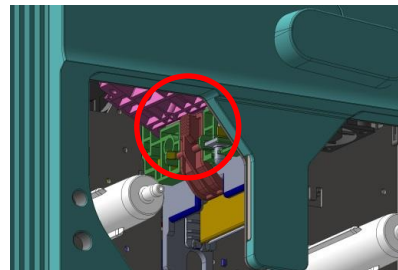

Figure 154 TPH replacement 4

D. TPH replacement 4

Please pull the detached print head out of Printer while turning the ribbon cartridge lock lever to the counterclockwise 90 degrees as Figure.



Figure 155 TPH replacement 5

E. TPH replacement 5

Please disconnect the print head cable from the detached print head as Figure and then connect the print head cable to a new print head.



Figure 156 TPH replacement 6

F. TPH replacement 6

Please install the new print head into Printer while turning the ribbon cartridge lock lever to the clockwise 90 degrees as Figure.

5.6 Laminator Head replacement



Figure 157 Laminator Head replacement 1

A. Laminator Head replacement 1

Please turn the film cartridge lock lever to the clockwise 90 degrees as Figure.



Figure 158 Laminator Head replacement 2

B. Laminator Head replacement 2

Please pull out the film cartridge as Figure.



Figure 159 Laminator Head replacement 3

C. Laminator Head replacement 3

Please detach the laminate head while pressing the laminate head detaching button as Figure.



Figure 160 Laminator Head replacement 4

D. Laminator Head replacement 4

Please pull the detached laminate head out of Laminator while turning the film cartridge lock lever to the counterclockwise 90 degrees as Figure.



Figure 161 Laminator Head replacement 5

E. Laminator Head replacement 5

Please disconnect 2 head cables from the detached laminate head as Figure and then connect the laminate head cables to a new laminate head.



Figure 162 Laminator Head replacement 6

F. Laminator Head replacement 6

Please install the new laminate head into Laminator while turning the film cartridge lock lever to the clockwise 90 degrees as Figure.

6. SMART-70 Specifications

6.1 SMART-70 Input Hopper

Capacity	Card	Max. 500 cards
	Feeding	Automatic
Card	Size	ISO CR80 (54mm x 86mm / 2.12" x 3.38")
	Thickness	0.38mm (15mil), 1.2mm (47mil)
	Type	PVC, Composite PVC, PET
Sensor	Residual Q'ty Sensor	Near Empty & Empty
	Detection Sensor	Cartridge Mount Status Detectable
System	Communication	USB, RS-232C
	Power	Free Voltage (AC100 / 220V, 50~60Hz) / 24V, 2A
	Temp. / Humidity	15~35°C / 35~70%
Security	Physical Lock	Cartridge
	Station Itself	Kensington Lock
Dimensions	Millimeter	170 (W) x 204 (L) x 548 (H)
	Inch	6.7 (W) x 8.0 (L) x 21.6 (H)
Weight	Kg/lbs.	Approx. 3.7 kg / 8.2 lbs.

6.2 SMART-70 Printer

Printing	Print Type	Direct Dye-Sublimation
	Print Area	Edge to Edge
	Resolution	300dpi
Card	Card Feeding	Automatic
	Card Size	ISO CR80 (54mm x 86mm / 2.12" x 3.38")
	Card Thickness	0.38mm (15mil), 1.2mm (47mil)
	Card Type	PVC, Composite PVC, PET
Print Speed	Monochrome	3.6 sec./card (1,000 cards/hour)
	YMCKO	18 sec./card (200 cards/hour), Max. 16 sec./card (225 card/hour)
	YMCKOK	24 sec./card (150 cards/hour), Max. 22 sec./card (164 cards/hour)
Capacity	Input Hopper: Card	500 cards
	Output Hopper: Card	Stacker: 100 cards/ *Optional Output Hopper: 500 cards
System	Memory	64MB RAM
	Interface	2 Line LCD / 4 Buttons / 1 LED Indicator

	Supported Platforms	Microsoft Windows 2000/ 2003/ XP/ Vista/ 7/ 8, Max OS, Linux
	Communication	USB, Ethernet
	Power Supply	Free Voltage (AC100 / 220V, 50~60Hz)
	Power Consumption	24V, 2A
	Temp. / Humidity	15~35°C / 35~70%
Security	Physical Lock	Print ribbon
	S/W	PC authentication, Password authentication
	Station Itself	Kensington Lock
Dimensions	Millimeter	240 (W) x 214 (L) x 305 (H)
	Inch	9.5 (W) x 8.4 (L) x 12 (H)
Weight	Kg/lbs.	Approx. 6.3 kg / 13.9 lbs.

6.3 SMART-70 Hybrid Flipper

System	Communication	USB, RS-232C
	Power Supply	Free Voltage (AC100 / 220V, 50~60Hz)
	Power Consumption	24V, 2A
	Temp. / Humidity	15~35°C / 35~70%
Security	Physical Lock	Cards
	Station Itself	Kensington Lock
Dimensions	Millimeter	110 (W) x 204 (L) x 305 (H)
	Inch	4.3 (W) x 8.0 (L) x 12 (H)
Weight	Kg/lbs.	Approx. 2.8 kg / 6.2 lbs.
Error Card Bin	Ejection device for faulty card is equipped inside Hybrid Flipper (Max. 30 card.)	

6.4 SMART-70 Laminator

Laminating	Type	Direct Heating Lamination
	Speed	14 sec./card (Single-sided Laminating)
Laminating Film	Type	Clear, Holographic
	Thickness	0.6mil, 1.0mil
	Capacity	500 cards/Roll
System	Interface	2 Line LCD / 4 Buttons / 1 LED Indicator
	Communication	USB, RS-232C

	Power Supply	Free Voltage (AC100 / 220V, 50~60Hz)
	Power Consumption	24V, 2A
	Temp. / Humidity	15~35°C / 35~70%
Security	Physical Lock	Laminating Film
	Station Itself	Kensington Lock
Dimensions	Millimeter	240 (W) x 214 (L) x 305 (H)
	Inch	9.5 (W) x 8.4 (L) x 12 (H)
Weight	Kg/lbs.	Approx. 6.1 kg / 13.4 lbs.

6.5 SMART-70 Output Hopper

Capacity	Card	Max. 500 cards
	Feeding	Automatic
Card	Size	ISO CR80 (54mm x 86mm / 2.12" x 3.38")
	Thickness	0.38mm (15mil), 1.2mm (47mil)
	Type	PVC, Composite PVC, PET
Sensor	Residual Q'ty Sensor	Full Space
	Detection Sensor	Cartridge Mount Status Detectable
System	Communication	USB, RS-232C
	Power	Free Voltage (AC100 / 220V, 50~60Hz) / 24V, 2A
	Temp. / Humidity	15~35°C / 35~70%
Security	Physical Lock	Cartridge
	Station Itself	Kensington Lock
Dimensions	Millimeter	149 (W) x 204 (L) x 548 (H)
	Inch	5.9 (W) x 8.0 (L) x 21.6 (H)
Weight	Kg/lbs.	Approx. 3.5 kg / 7.6 lbs.

Specifications and availability may change without notice.



Office: Room 601, 50, Digital-ro 33-gil, Guro-gu, Seoul, 152-742, Korea

Tel: +82-2-6099-3700 Fax: +82-2-6099-3717 E-mail: sales@idp-corp.com